

An Atlas of Structures, Mechanisms, and Robots

Dr. Bob Williams, williar4@ohio.edu

Mechanical Engineering, Ohio University

© 2023 Dr. Bob Productions

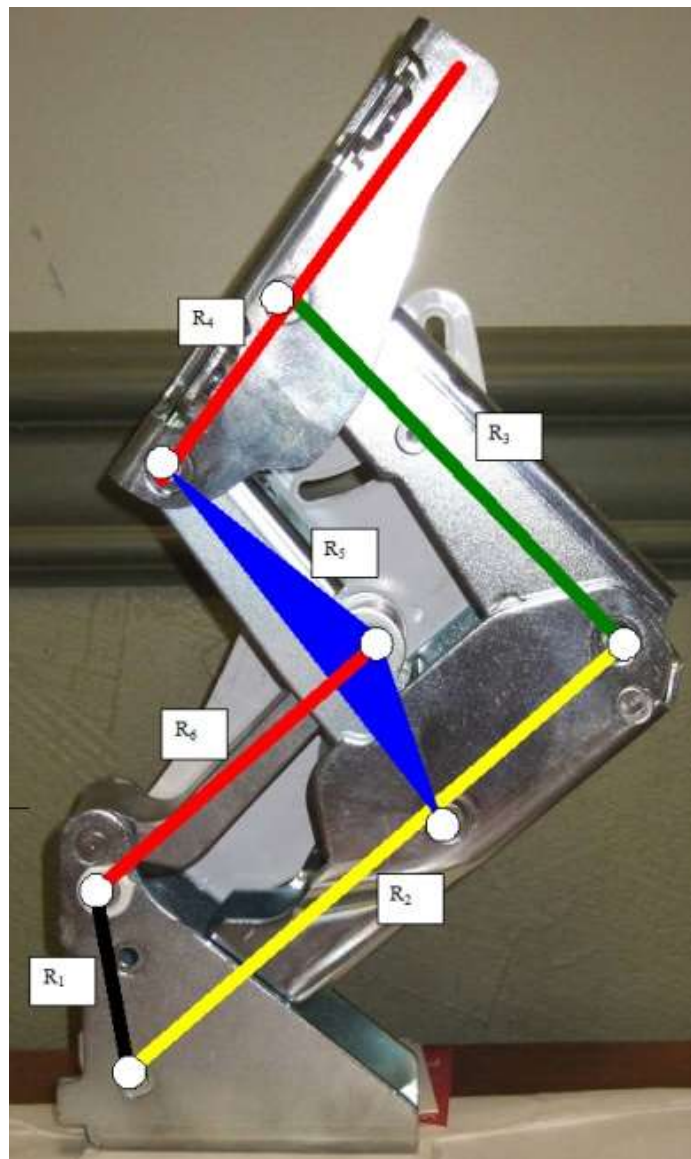

Hettich Hinge Watt I 6-bar Mechanism

Table of Contents

ZERO-DOF (OR LESS) STRUCTURES	3
ONE-DOF MECHANISMS	4
MULTI-DOF ROBOTS	21
REAL-WORLD MECHANISMS / KINEMATIC DIAGRAMS	23
MATLAB SIMULATION/ANIMATION GALLERY.....	24

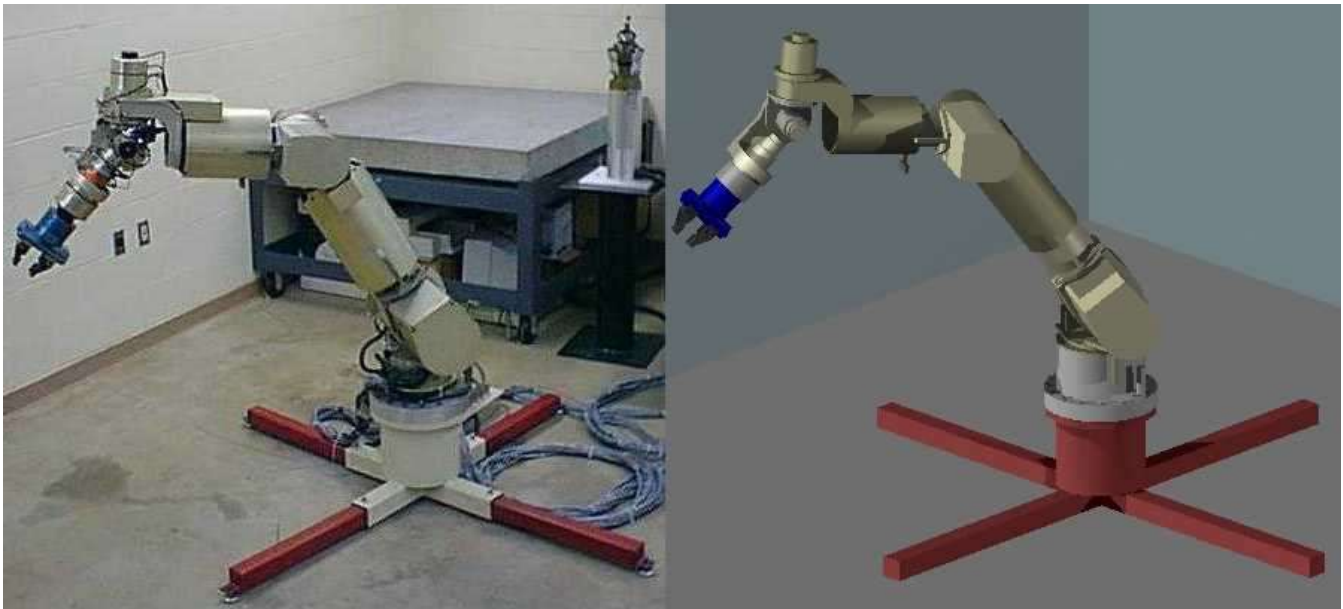

NASA 8-dof ARMII Robot

Zero-dof (or less) Structures

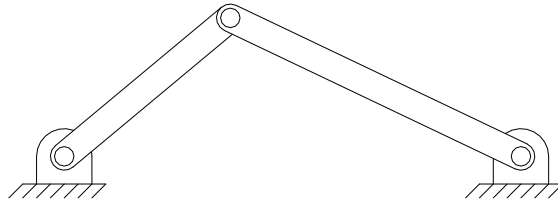

Statically Determinate Structure

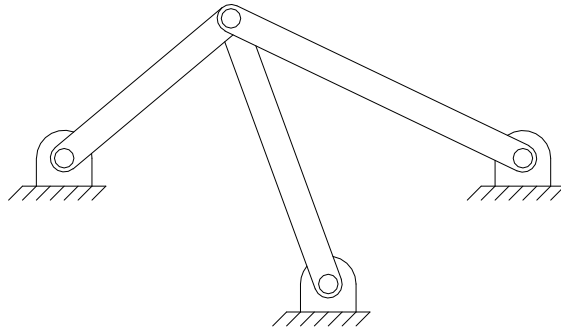

Statically Indeterminate Structure

One-dof Mechanisms

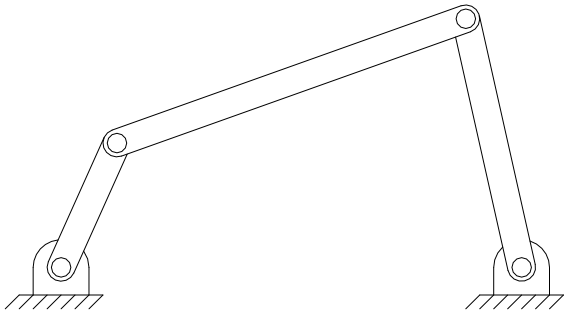

4-Bar Mechanism

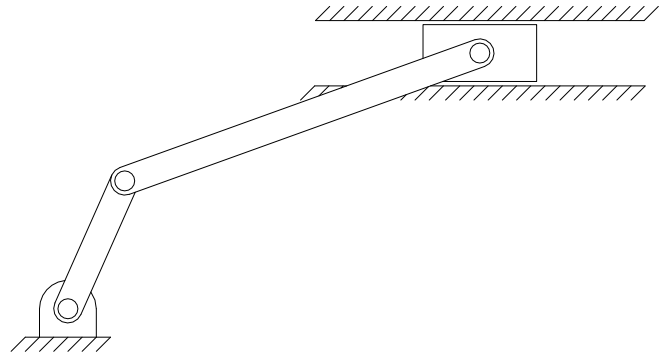

Offset Slider-Crank Mechanism

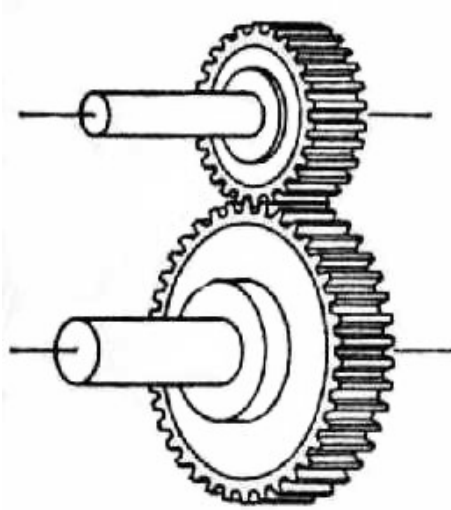

Spur Gear Mechanism

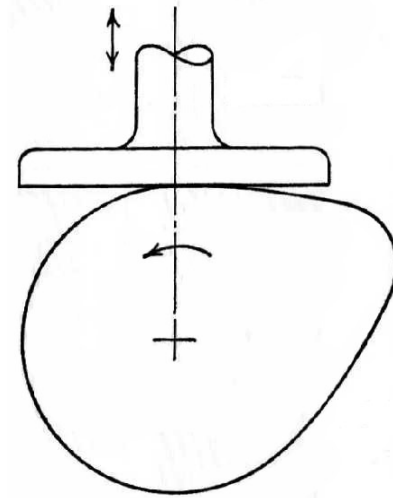

Cam-and-Follower Mechanism

The Four Slider-Crank Mechanism Inversions

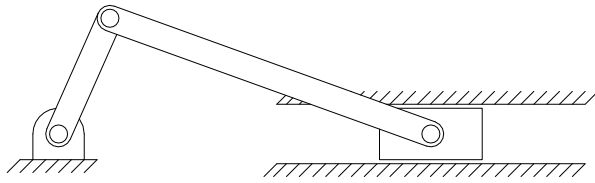

Slider-Crank Mechanism Inversion 1

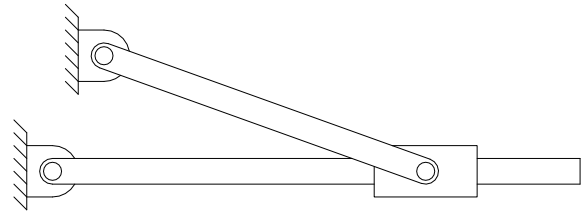

Slider-Crank Mechanism Inversion 2

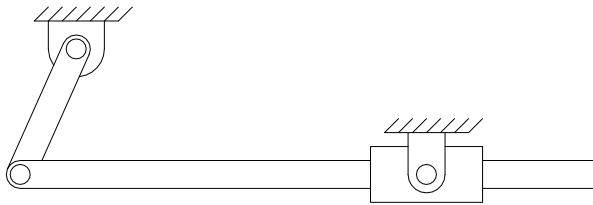

Slider-Crank Mechanism Inversion 3

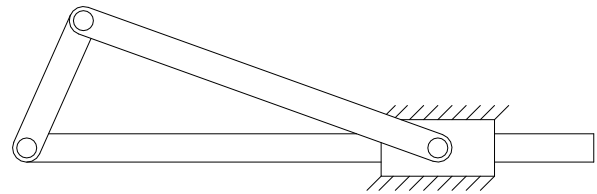

Slider-Crank Mechanism Inversion 4

Two Mechanisms with Slotted-Pin Joints

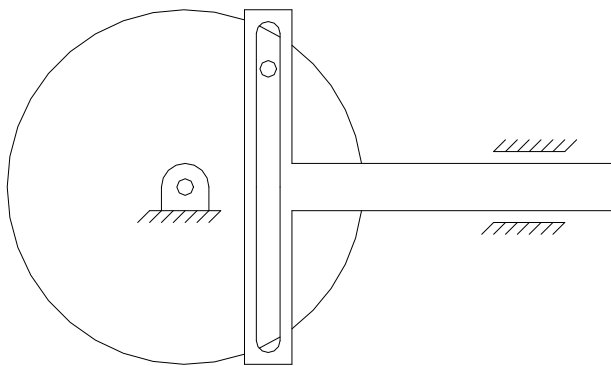

Scotch-Yoke Mechanism

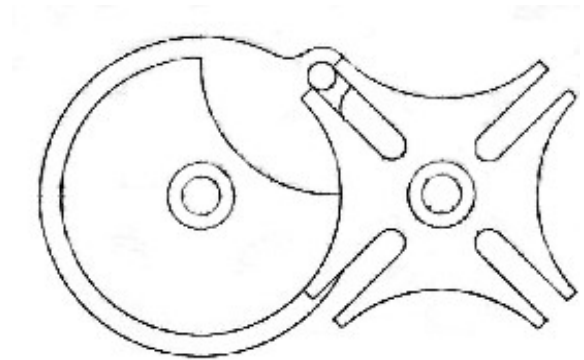

Geneva Wheel Mechanism

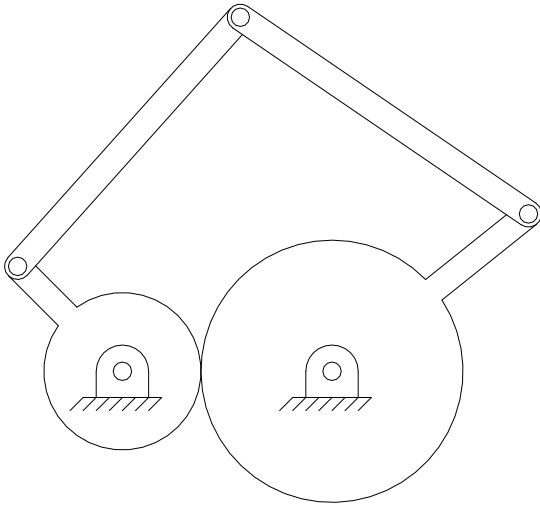
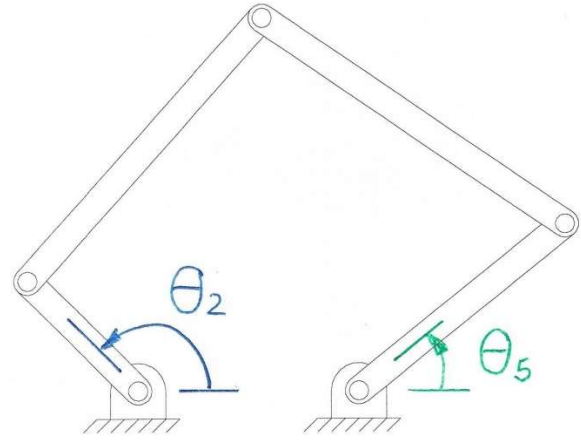
Geared 5-Bar Mechanism vs. 5-Bar Robot**Geared 5-Bar Mechanism****2-dof 5-Bar Parallel Robot**

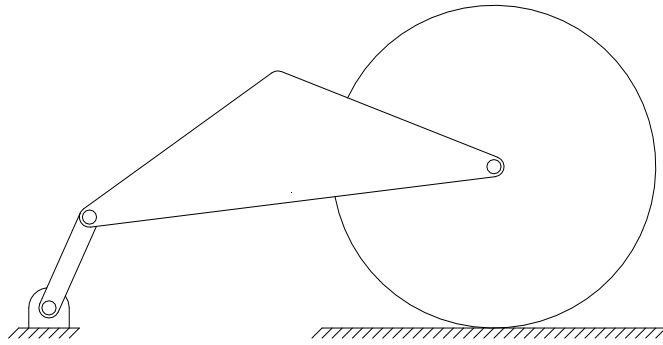

4-Bar Rolling Mechanism

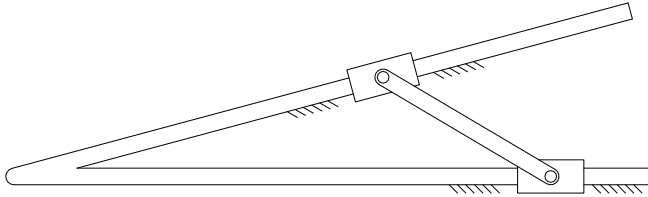

Dual-Slider Mechanism

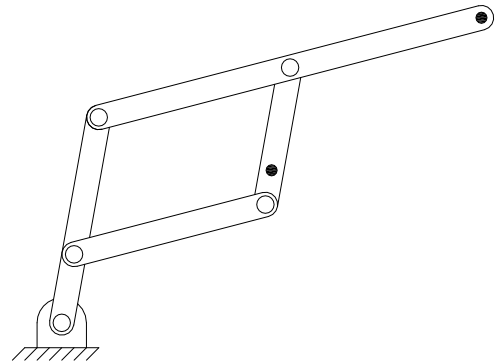

Pantograph Robot

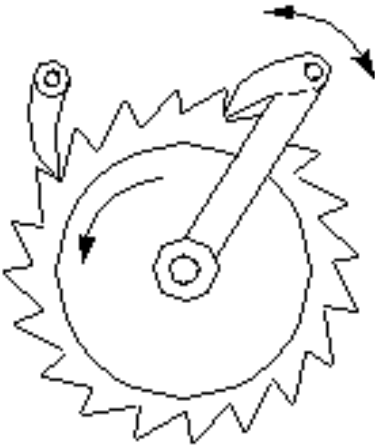

Ratchet Mechanism

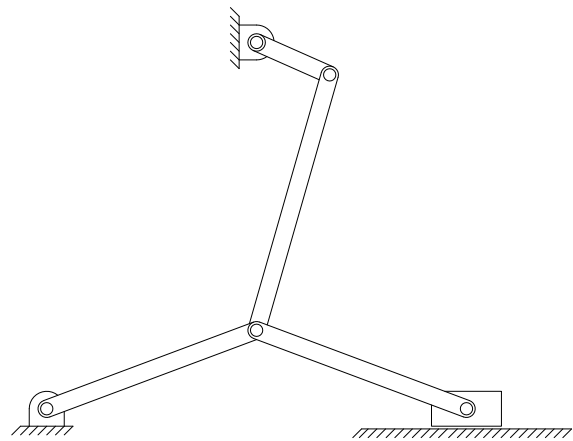

Toggle Mechanism

Five Straight-Line Mechanisms

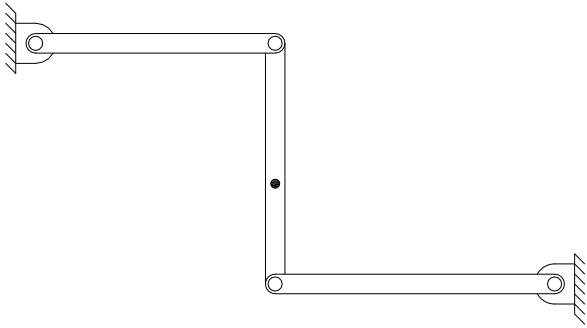

**Watt Straight-Line Mechanism
(approximate)**

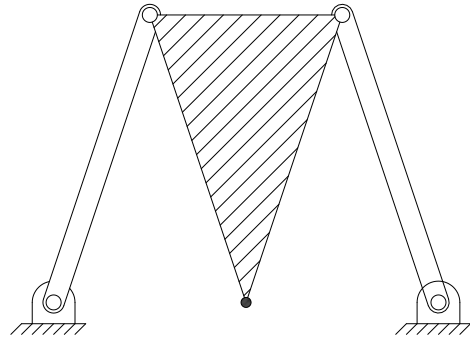

**Roberts Straight-Line Mechanism
(approximate)**

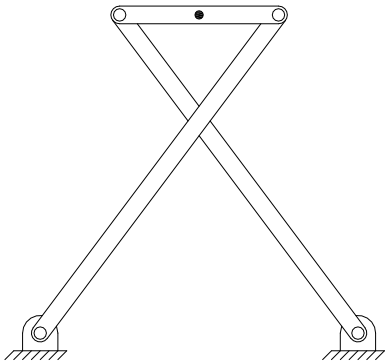

**Chebyshev Straight-Line Mechanism
(approximate)**

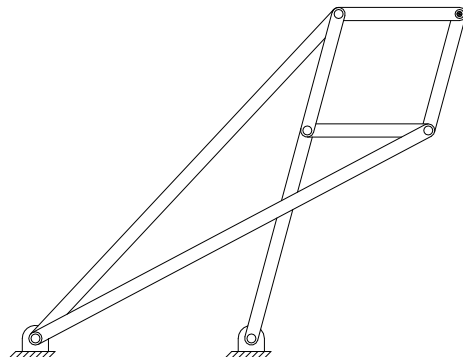

**Peaucellier Straight-Line Mechanism
(exact)**

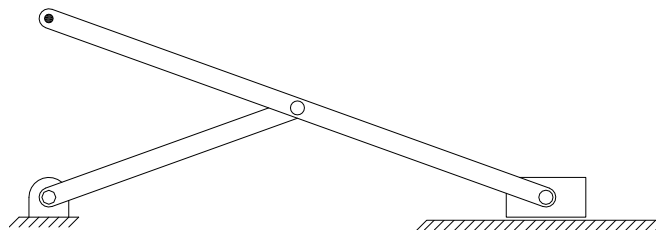

**Scott-Russell Straight-Line Mechanism
(exact)**

Three Quick-Return Mechanisms

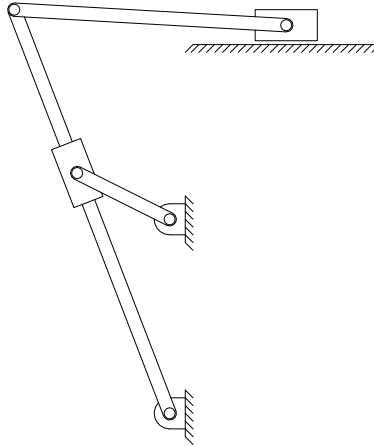

Crank-Shaper Quick-Return Mechanism

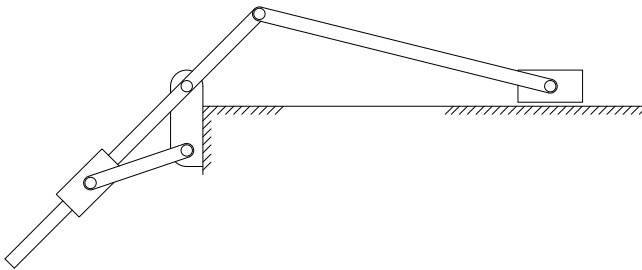

Whitworth Quick-Return Mechanism

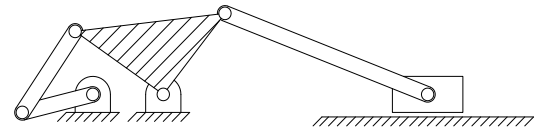

Drag-Link Quick-Return Mechanism

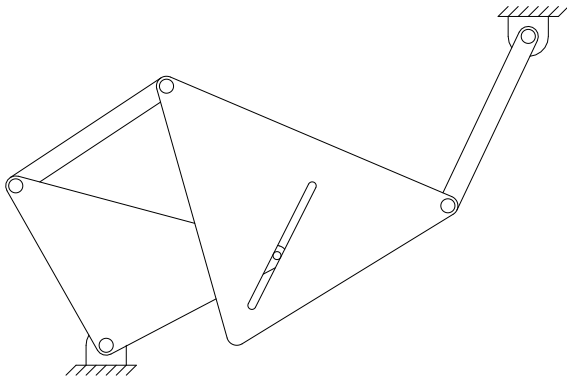

5-bar Slotted Mechanism

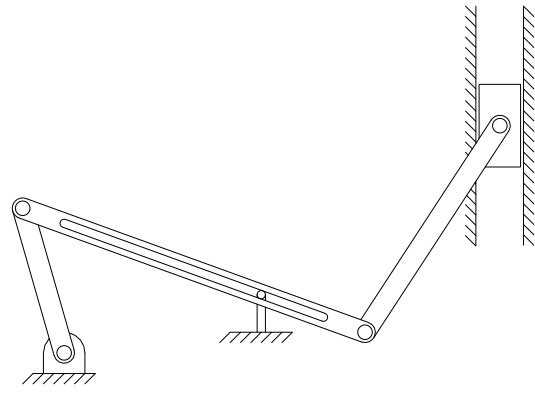

5-bar Slotted Slider Mechanism

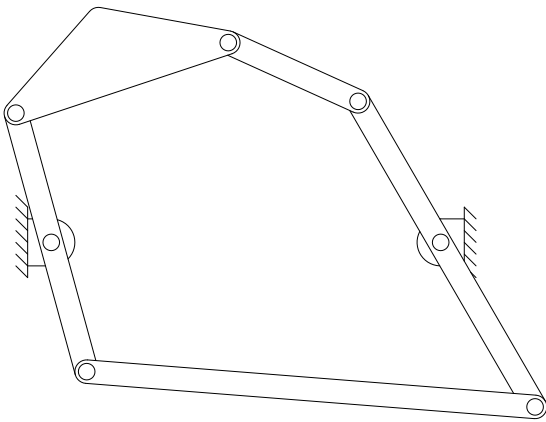

6-bar Mechanism

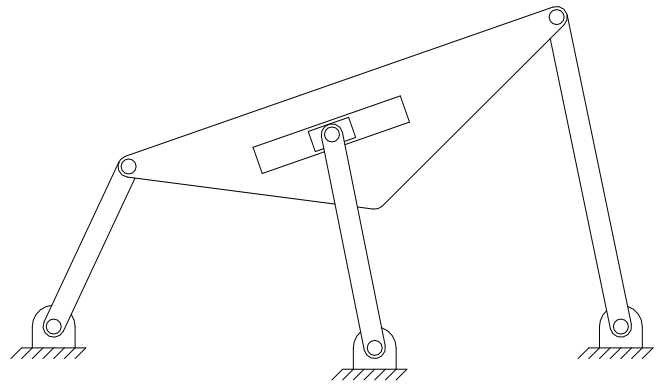

6-bar Single-Slider Mechanism

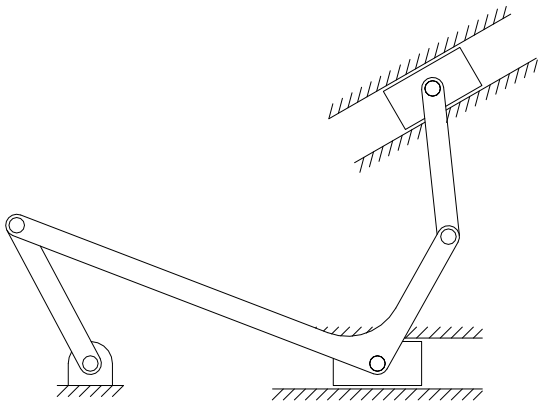

6-bar Crank Dual-Slider Mechanism

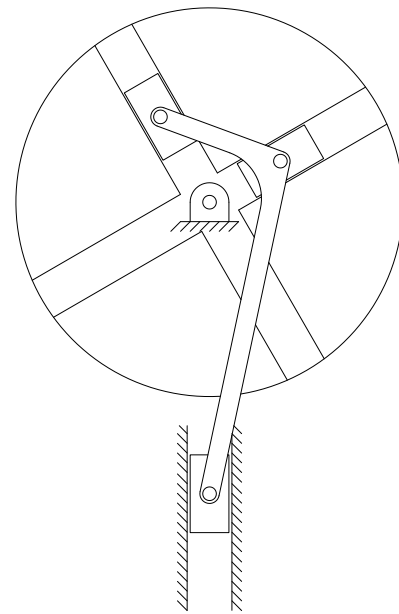

6-bar Crank Triple-Slider Mechanism

The Five Classical 6-Bar Mechanisms

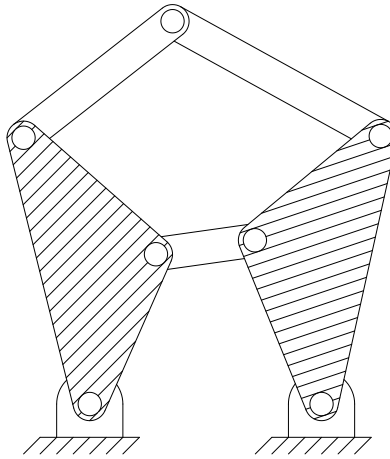

Stephenson I 6-Bar Mechanism

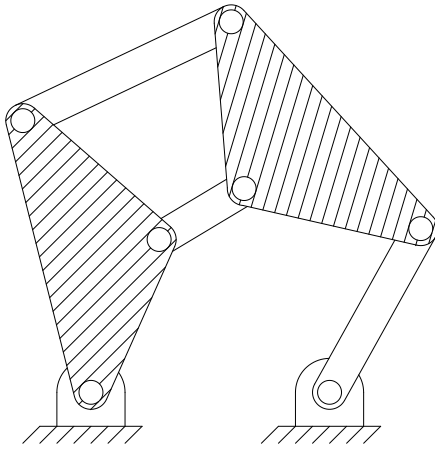

Stephenson II 6-Bar Mechanism

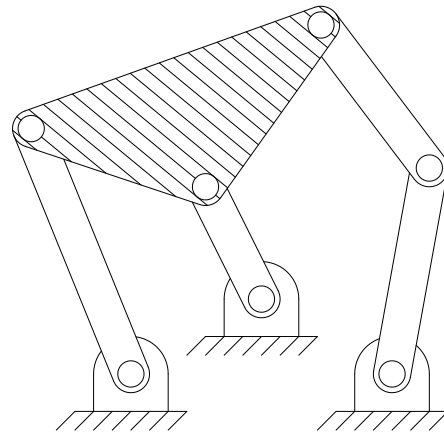

Stephenson III 6-Bar Mechanism

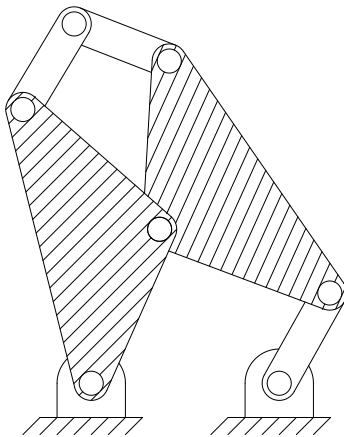

Watt I 6-Bar Mechanism

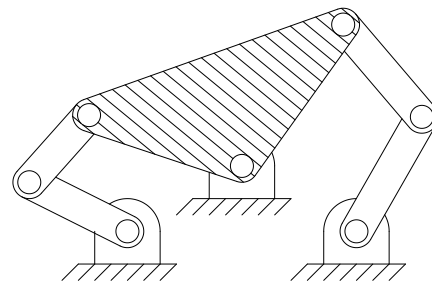

Watt II 6-Bar Mechanism

Some Real-World 4-Bar Mechanisms

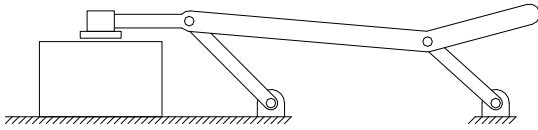

4-Bar Clamp Mechanism

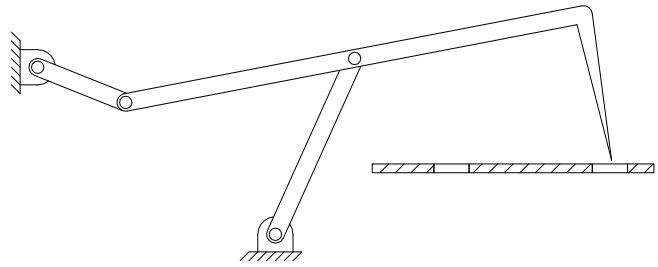

4-Bar Film-Advance Mechanism

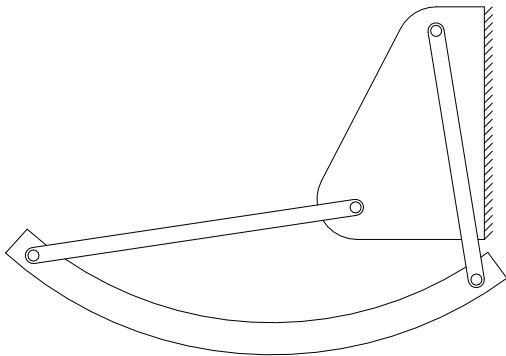

4-Bar Aircraft Carry-on Bin Mechanism

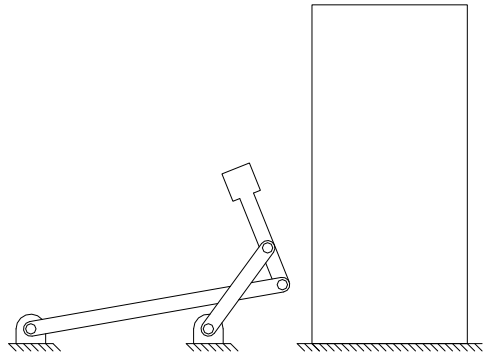

4-Bar Bass Drum Pedal Mechanism

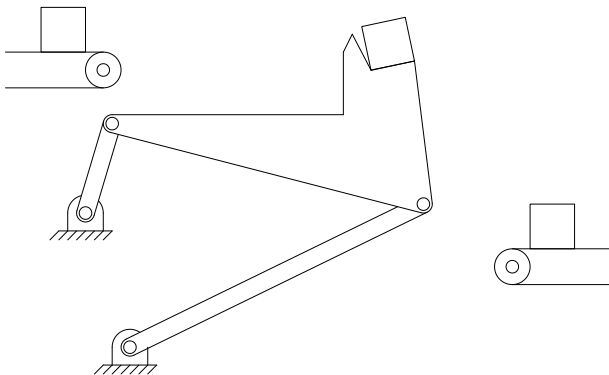

4-Bar Conveyor Transfer Mechanism

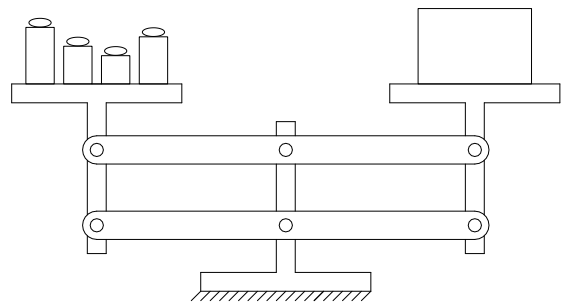

Dual 4-bar Balance Scale Mechanism

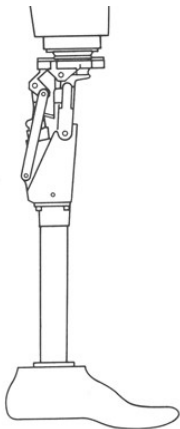

4-Bar Knee Prosthesis

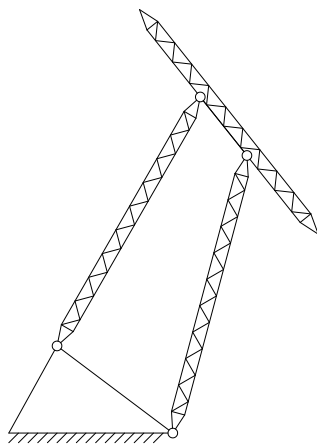

4-Bar Crane

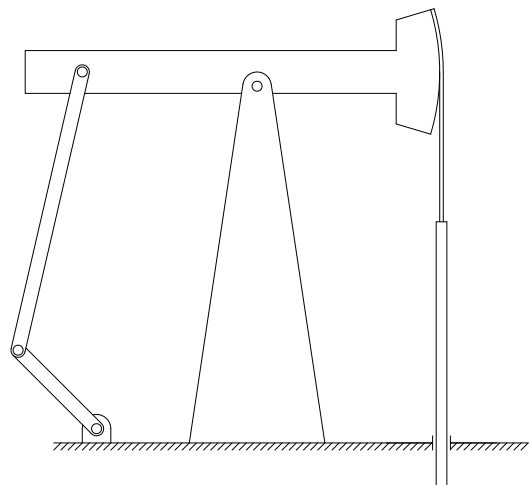

4-bar Horsehead Pump

Some Real-World 4-Bar Mechanisms (cont.)



[How does an Oscillating Fan work](#)

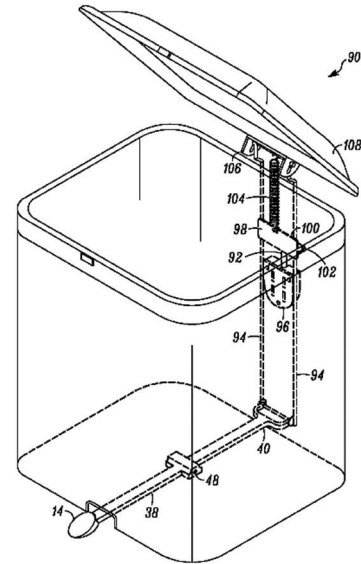

[US08136688-20120320-D00000.png](#)

4-Bar Oscillating Fan Mechanism

4-Bar Trashcan Mechanism

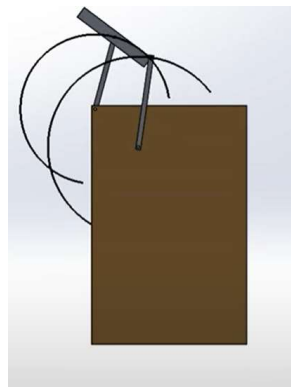
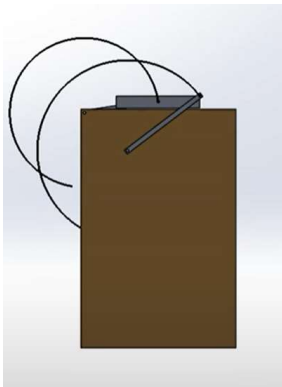

www.youtube.com/watch?v=re0o4S4mw4

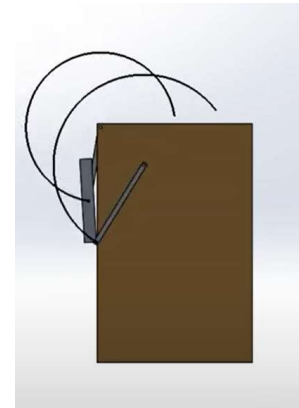

Another 4-Bar Trashcan Mechanism

Some Real-World Slider-Crank Mechanisms, all 4 inversions

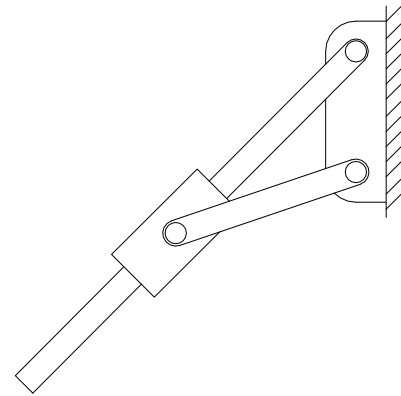
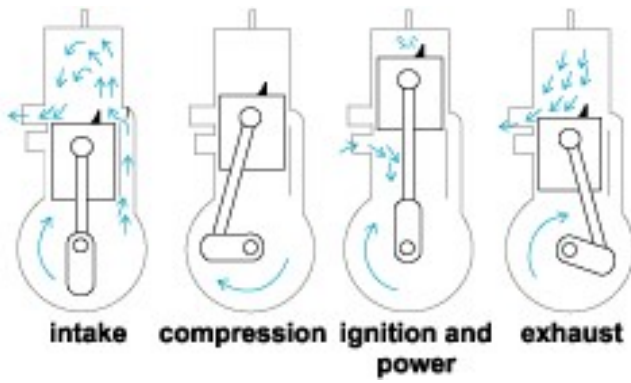

**4-Stroke Internal Combustion Engine Mechanism
S-C Inversion 1**

**Whitworth Mechanism
S-C Inversion 2**

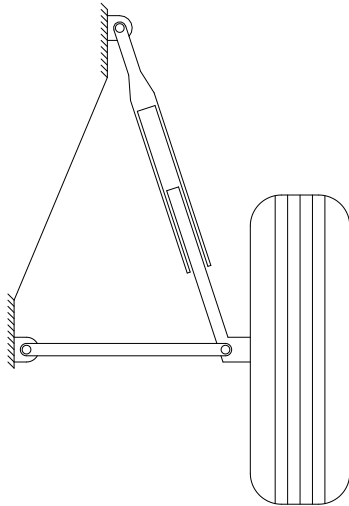

**MacPherson Strut Mechanism
S-C Inversion 3**

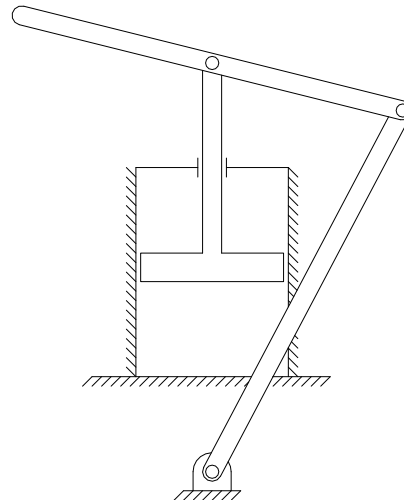

**Pump Mechanism
S-C Inversion 4**

Some Real-World Slider-Crank Mechanisms (cont.)

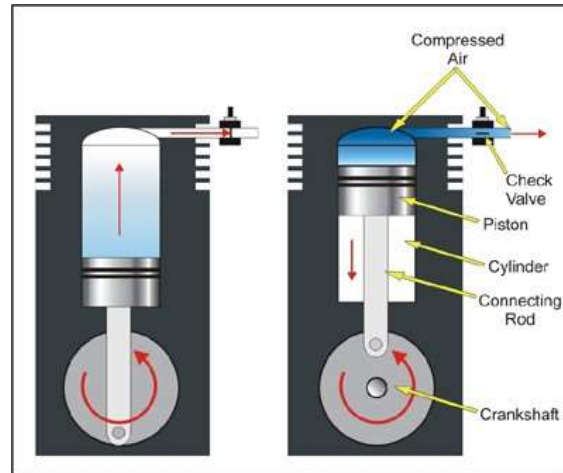

Air Compressor Mechanism
S-C Inversion 1

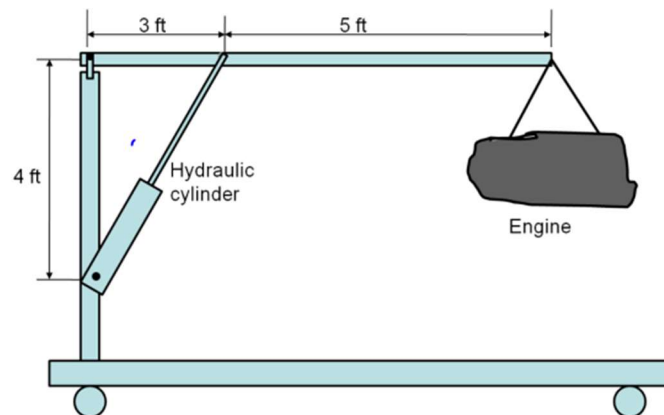

<media/ca4/ca45002e-e065-4da3-b020-47b24b372ede/phpmz23oG.png>

Engine Hoist Mechanism
S-C Inversion 3

Real-World Geared 5-Bar Mechanism

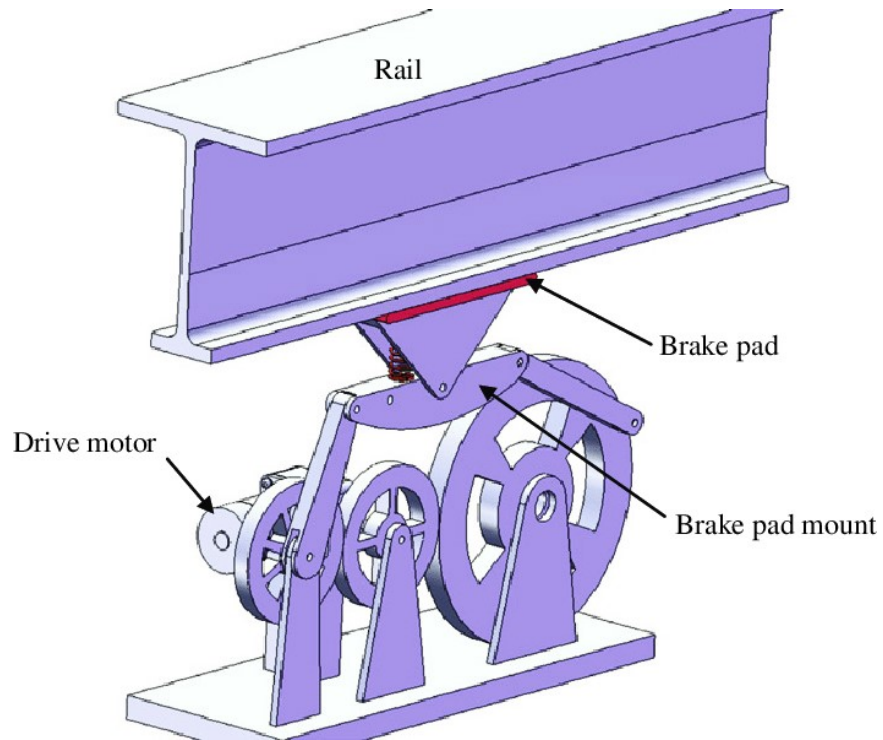

[geared five-bar mechanism - Bing images](#)

Overhead Traveler Braking Geared 5-Bar Mechanism

Some Real-World 6-Bar Mechanisms

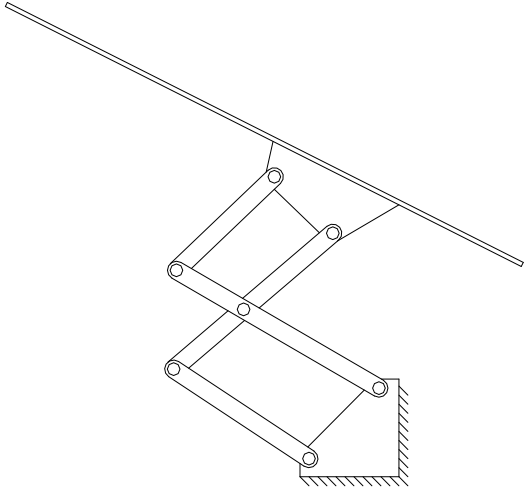

6-bar Car Hood Mechanism

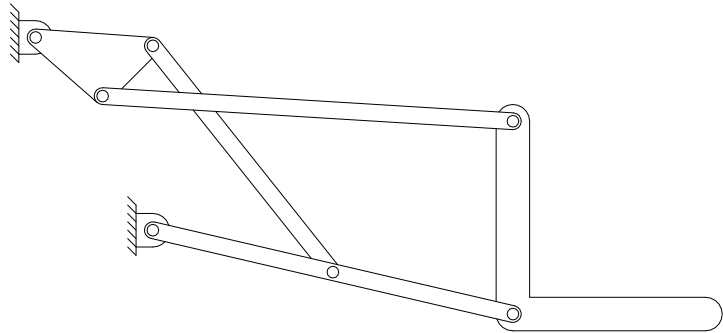

6-bar Lift Mechanism

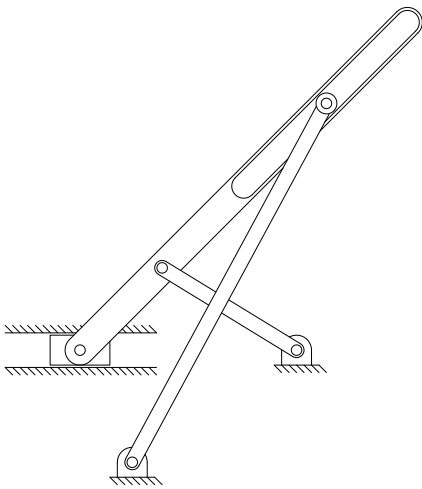

6-bar Window Mechanism

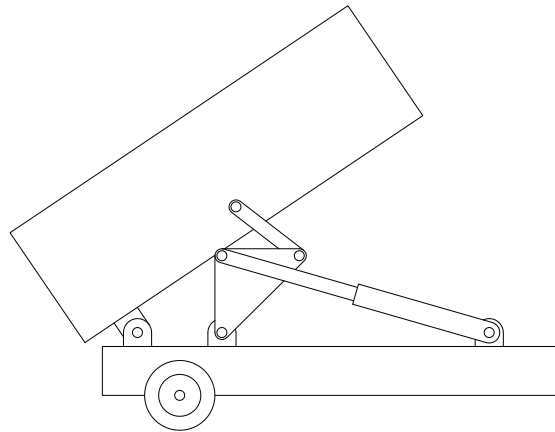

6-bar Dump Truck Mechanism

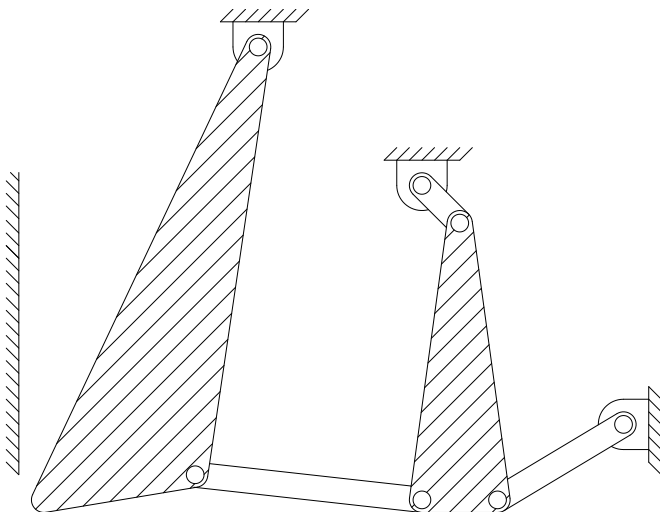

6-bar Rock Crusher Mechanism

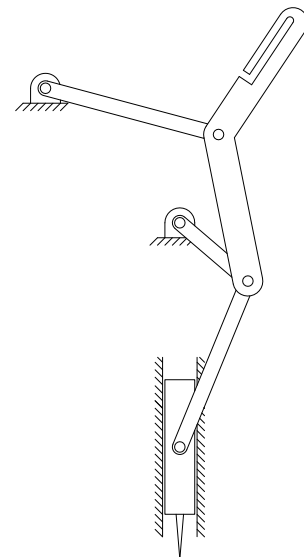

6-bar Sewing Machine Mechanism

Some Real-World 6-Bar Mechanisms (cont.)

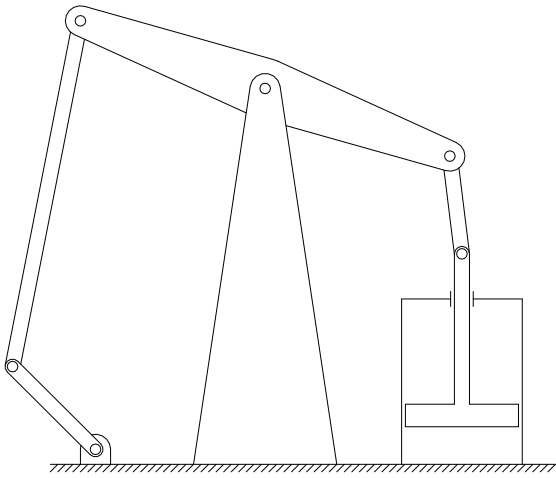

6-bar Watt Steam Engine Mechanism

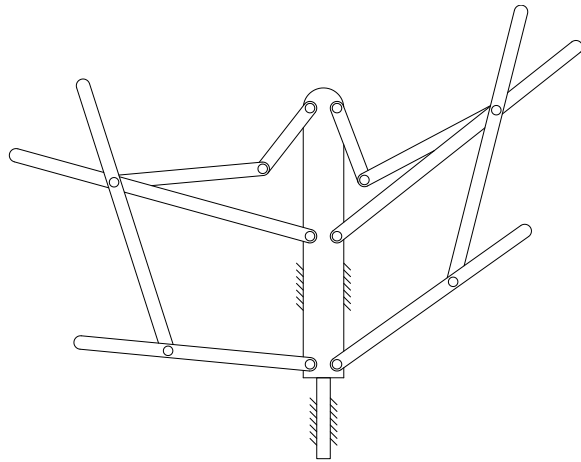

Dual 6-bar Mechanism Collapsible Music Stand

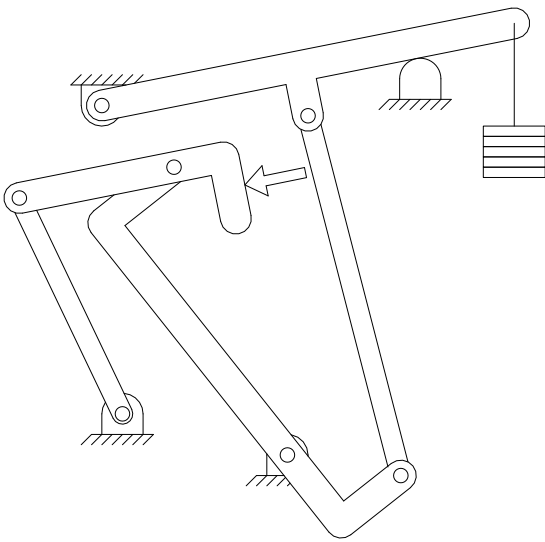

6-bar Leg Press Mechanism

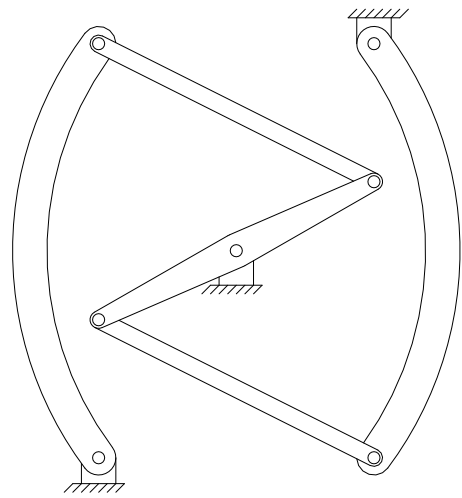

6-bar Drum Brake Mechanism

Some Real-World 7-Bar Mechanisms

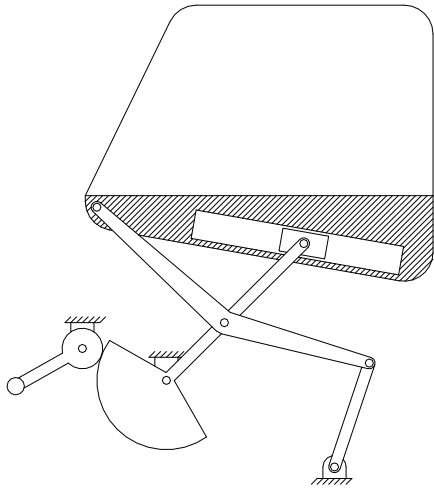

7-bar Car Window Mechanism

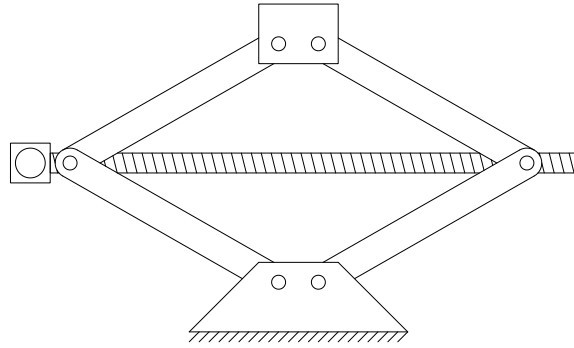

7-bar Car Jack Mechanism

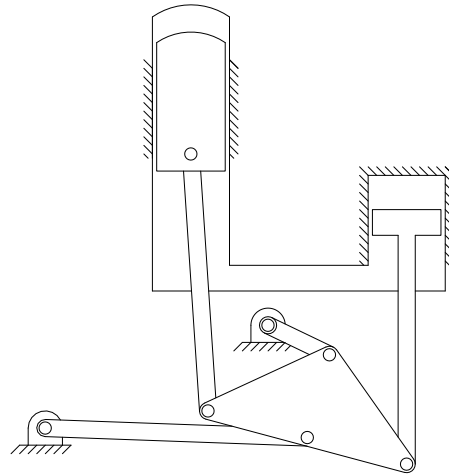

7-bar Ross Stirling Engine Mechanism

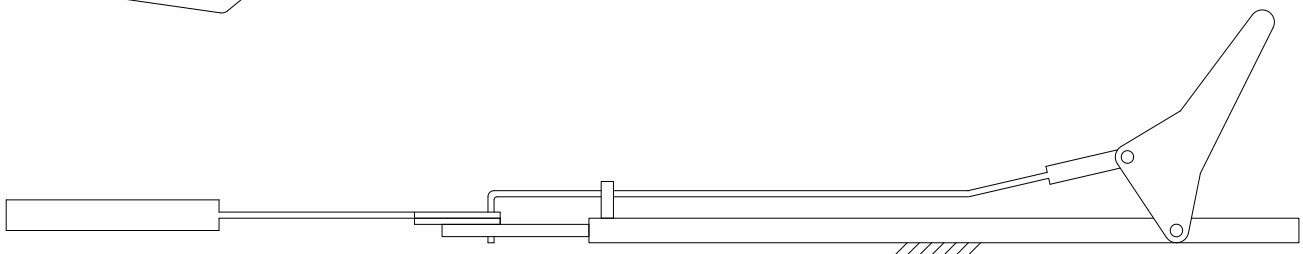
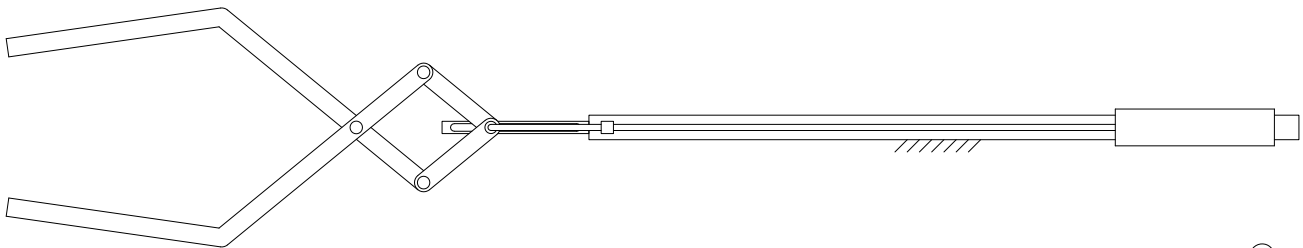

7-bar Grabber/Extender Compound Mechanism

Some Real-World 8-Bar Mechanisms

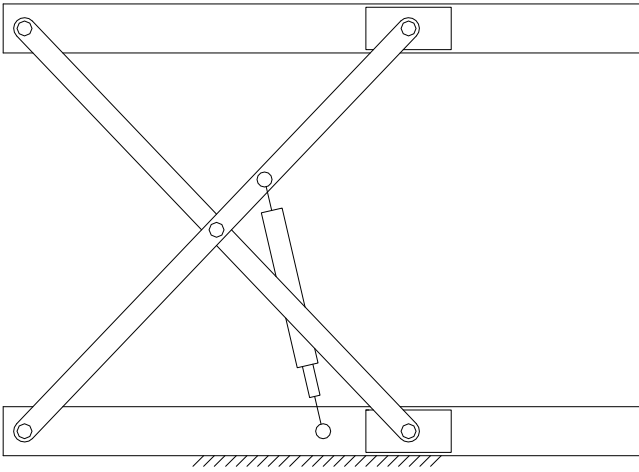

8-bar Scissor-Lift Mechanism

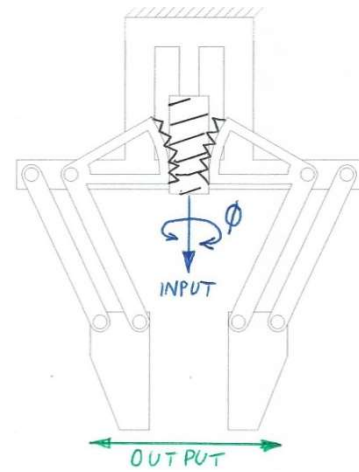

8-bar Robot Gripper Mechanism

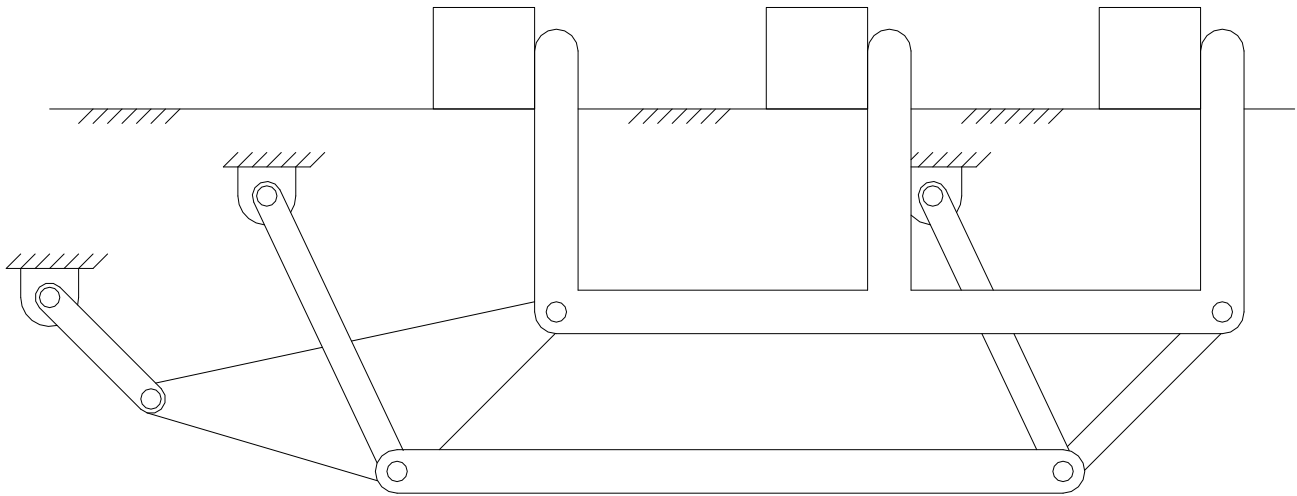

8-Bar Straight-Line Transfer Mechanism

Multi-dof Robots

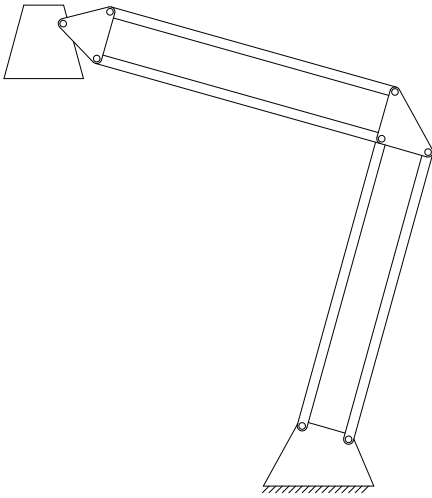

3-dof 8-bar Desk Lamp Robot

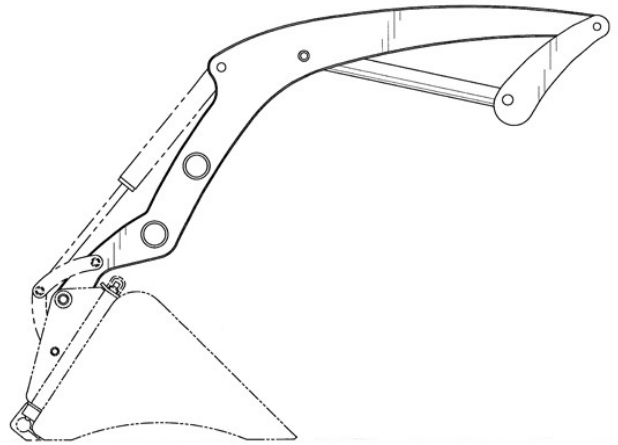

2-dof 9-bar Front-End Loader Robot

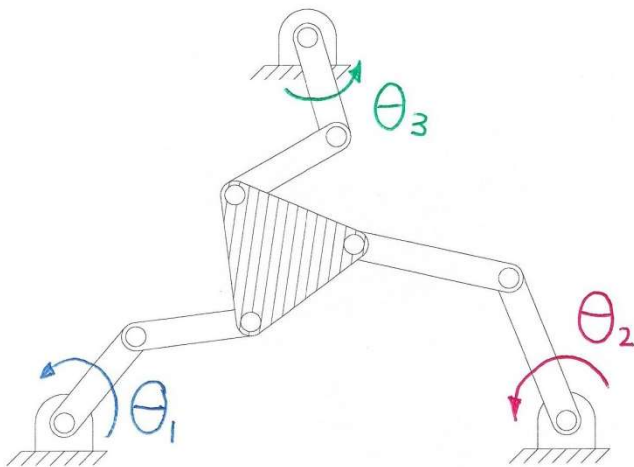

3-dof 3-RRR Parallel Robot

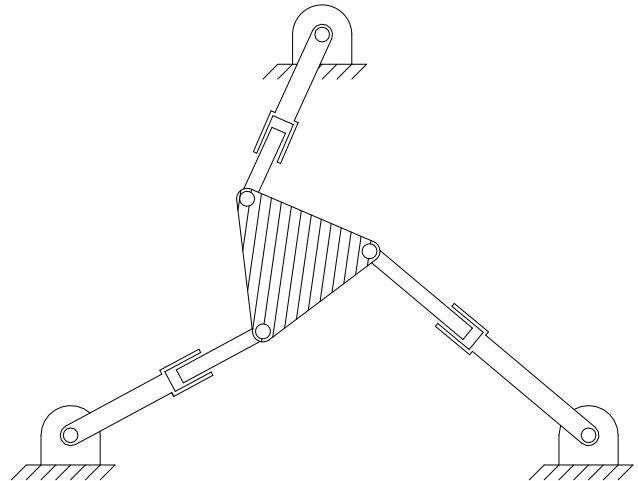

3-dof 3-RPR Parallel Robot

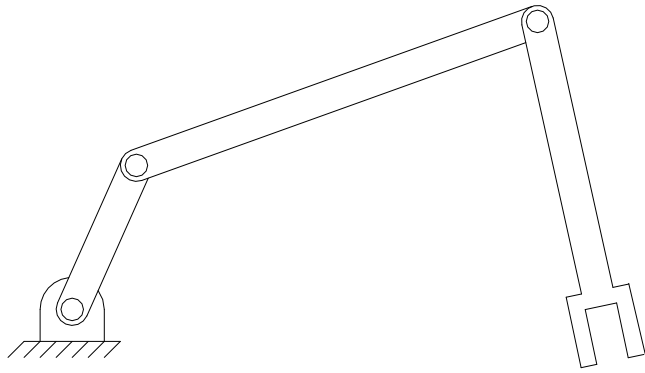

Planar 3-dof Robot



Adept 4-dof SCARA Robot

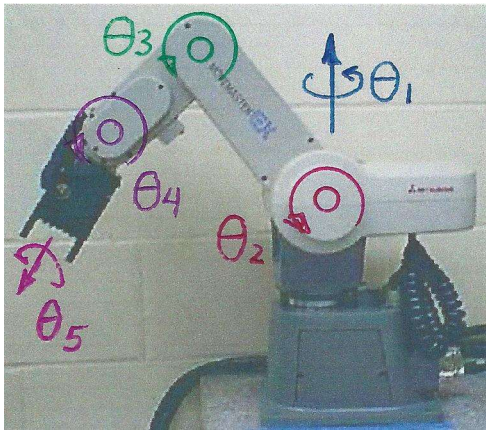

Mitsubishi 5-dof Robot

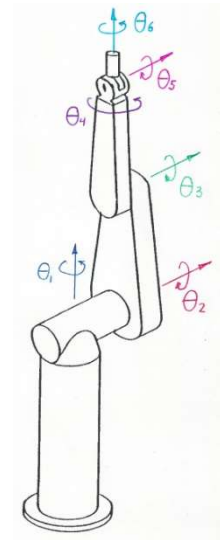

PUMA 6-dof Robot

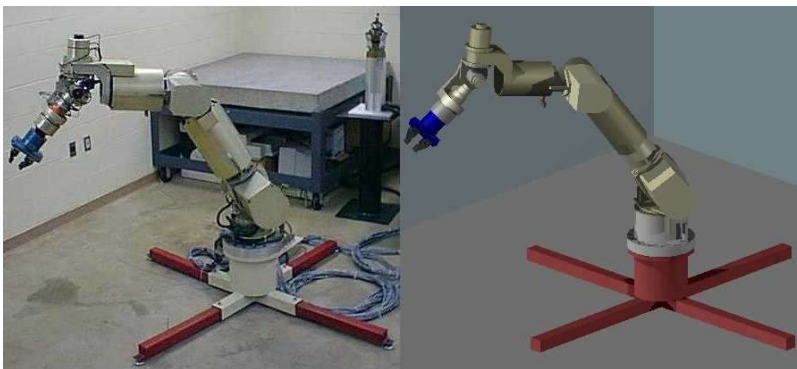

NASA 8-dof ARMII Robot

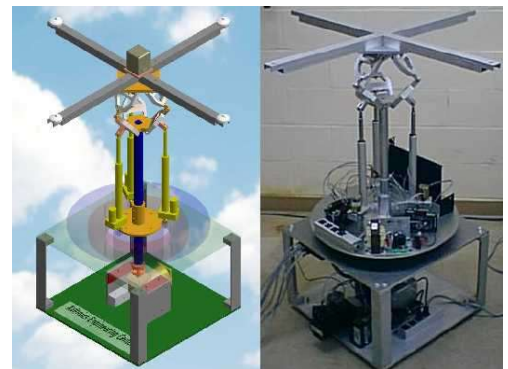

3-dof Carpal Wrist Robot

Real-World Mechanisms / Kinematic Diagrams

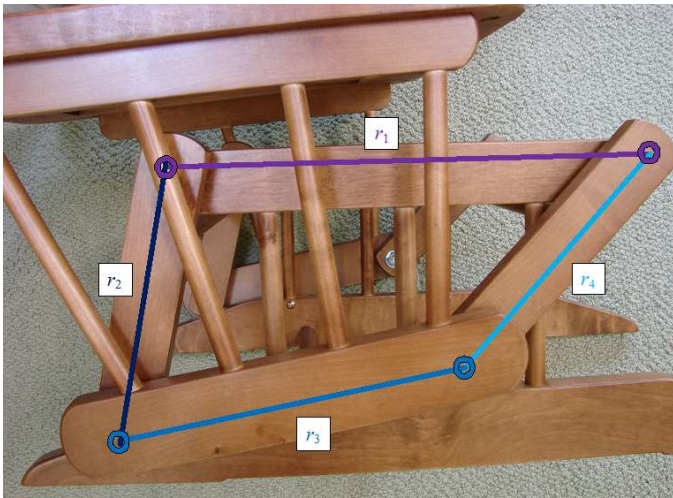

4-bar Glider-Rocker Mechanism



Bicycle/Human Leg 4-bar Mechanism (lock ankle)

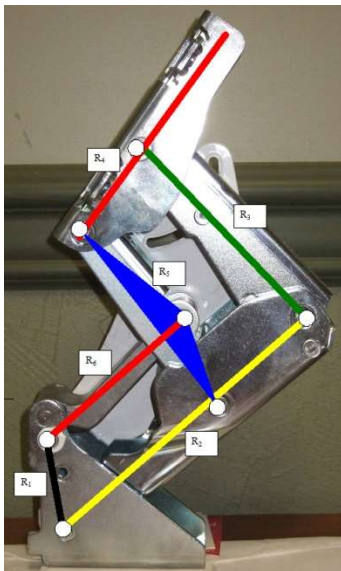

Hettich Hinge Watt I 6-bar Mechanism



Mountain Bike Rear Suspension Mechanism

MATLAB Simulation/Animation Gallery

All of the following MATLAB graphics/animations were created by Dr. Bob at Ohio University. These are presented according to the Ohio University course they support.

ME 3011 Kinematics & Dynamics of Machines and Introduction to Vibrations

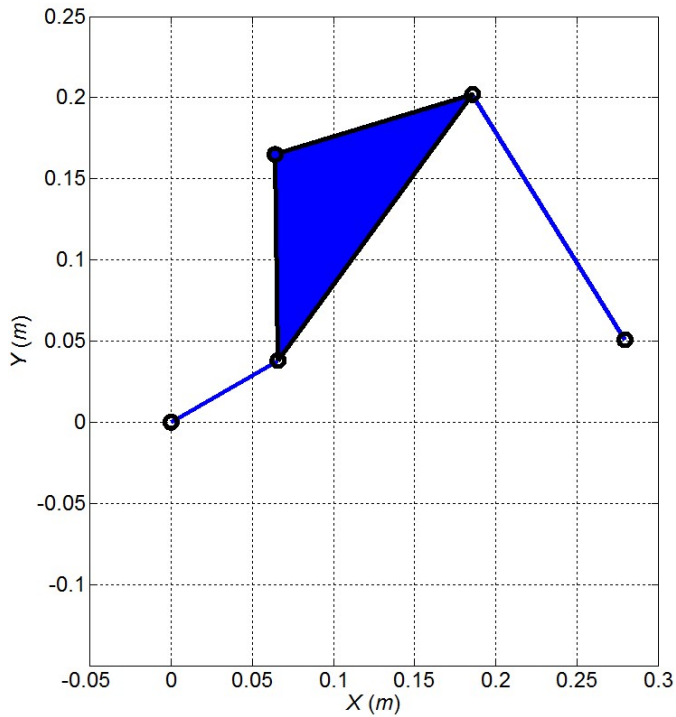

Open Branch

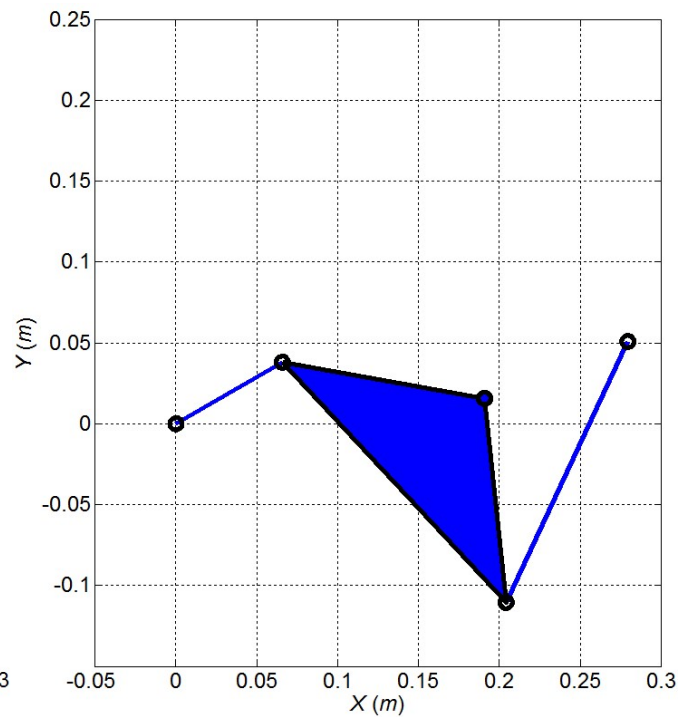

Crossed Branch

Four-Bar Mechanism

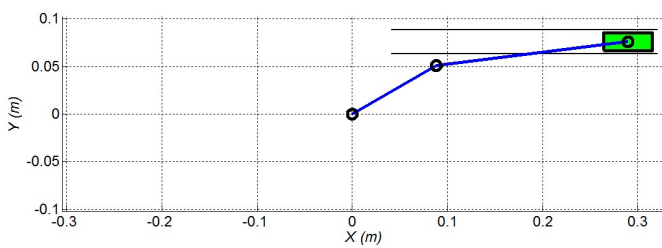

Right Branch

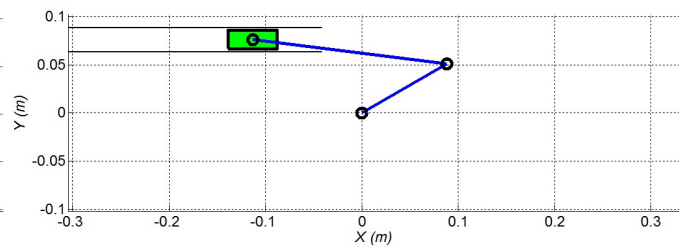

Left Branch

Slider-Crank Mechanism

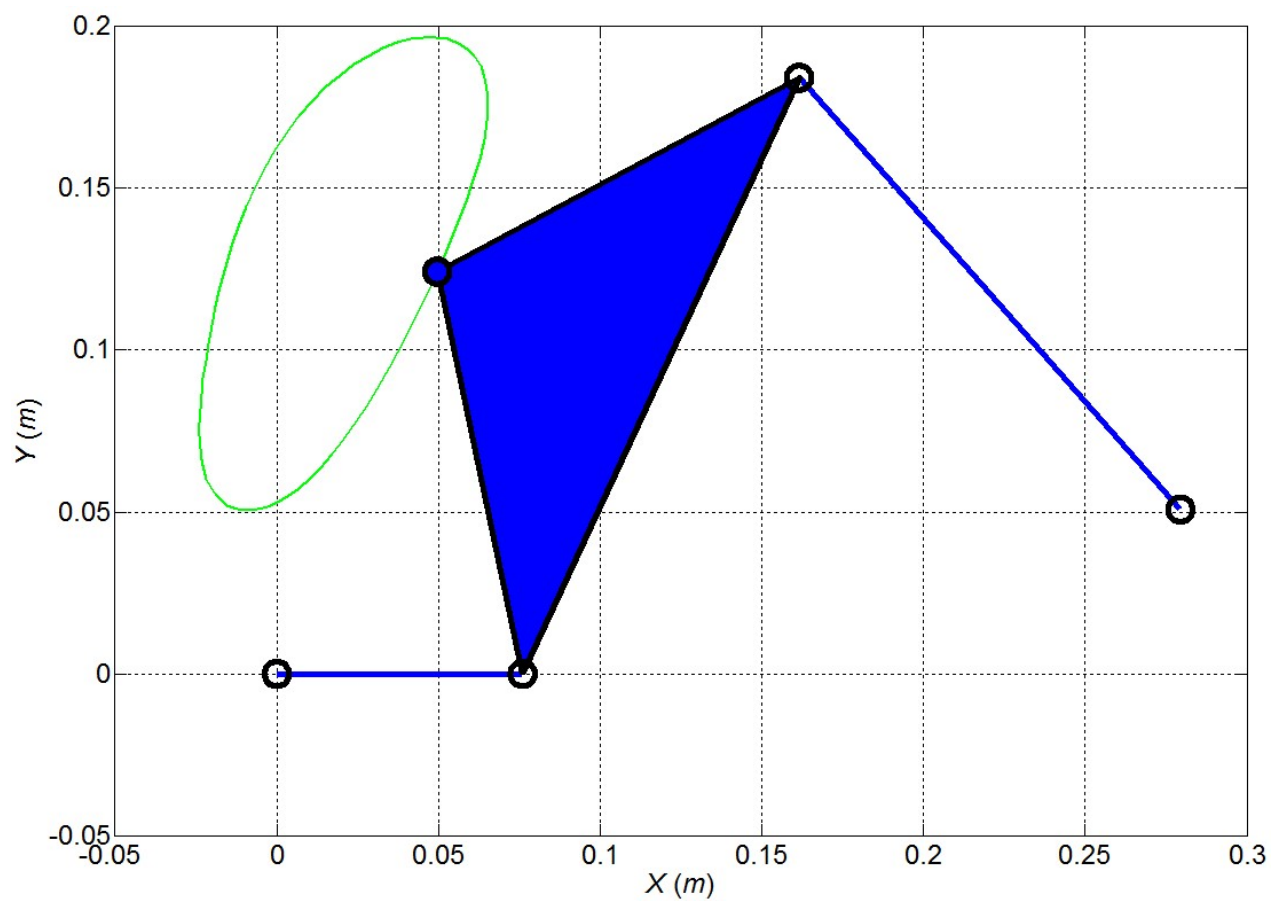
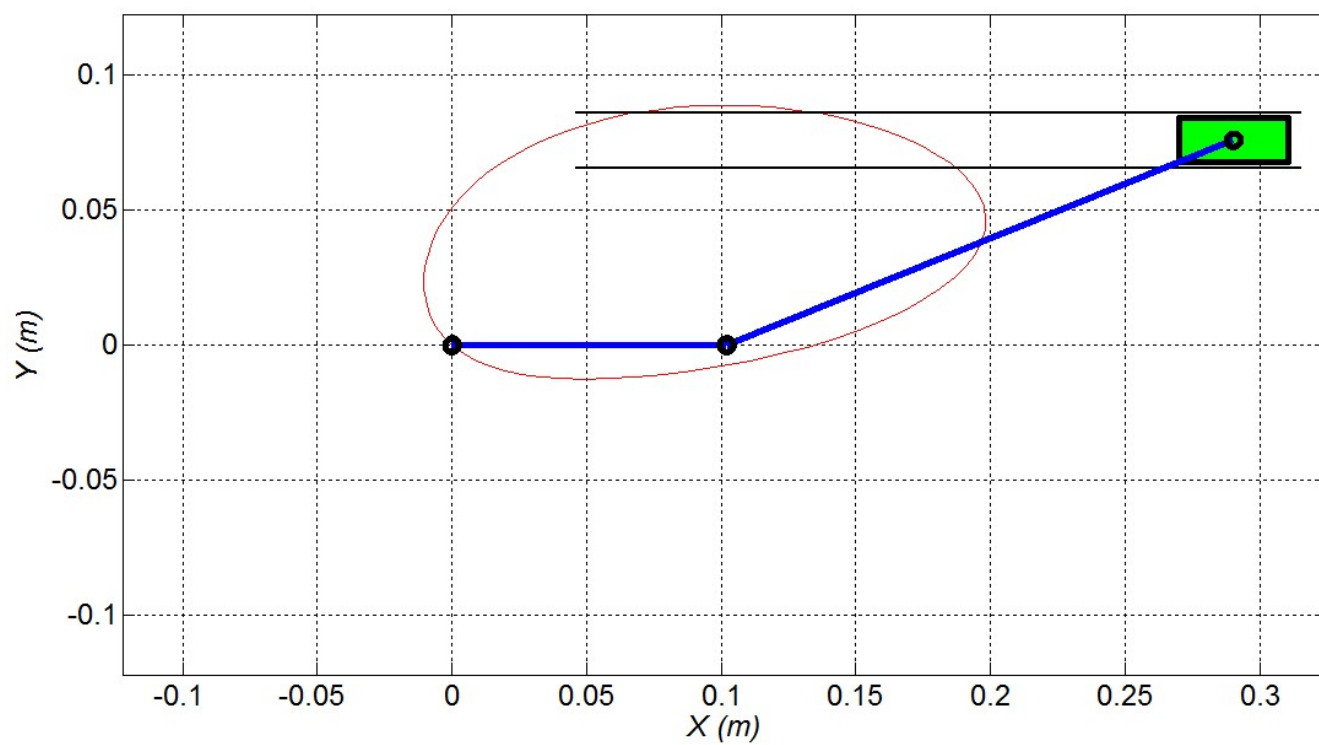
**Four-Bar Mechanism Coupler Curve****Slider-Crank Mechanism Coupler Curve**

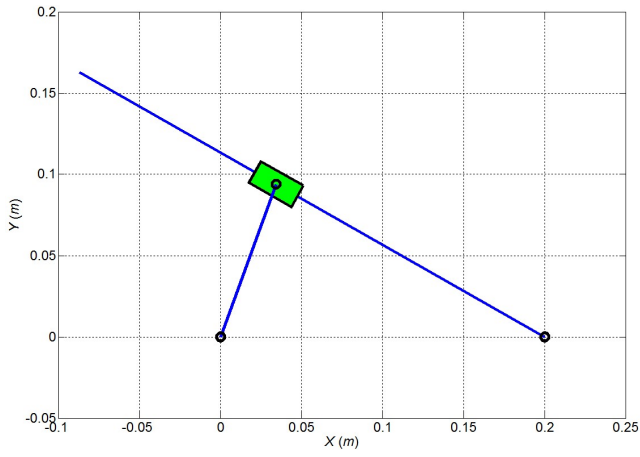

Slider-Crank Mechanism, Inversion 2

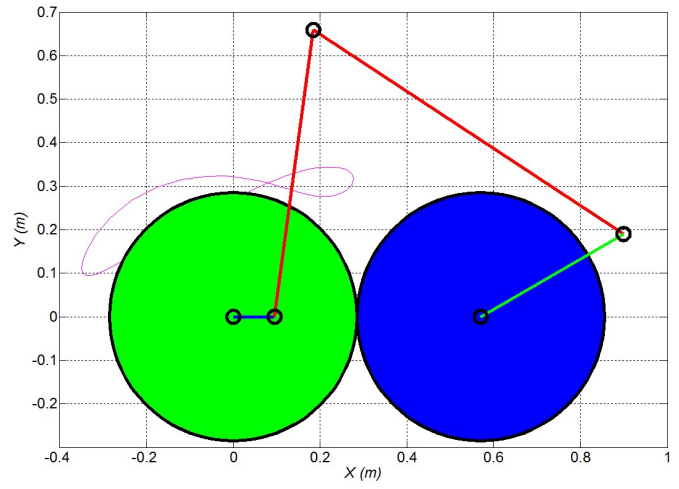

Geared Five-Bar Mechanism

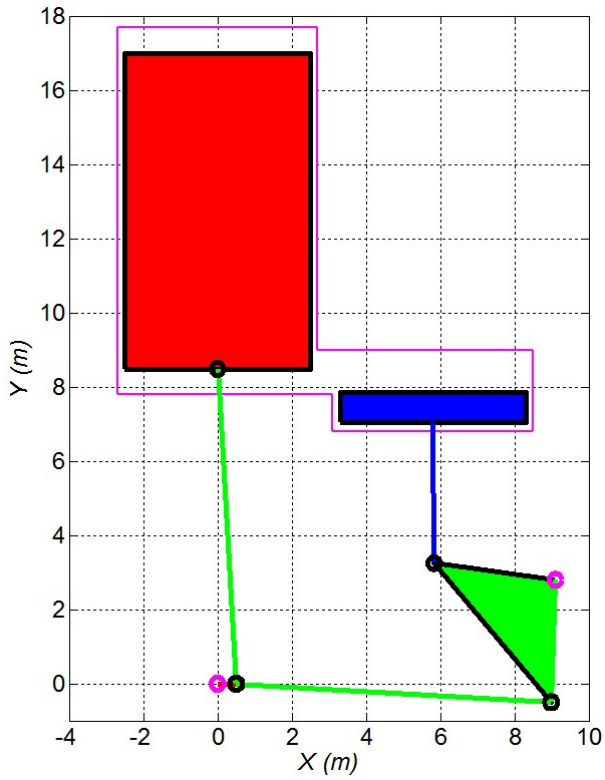

Ross-Yoke Stirling Engine Mechanism

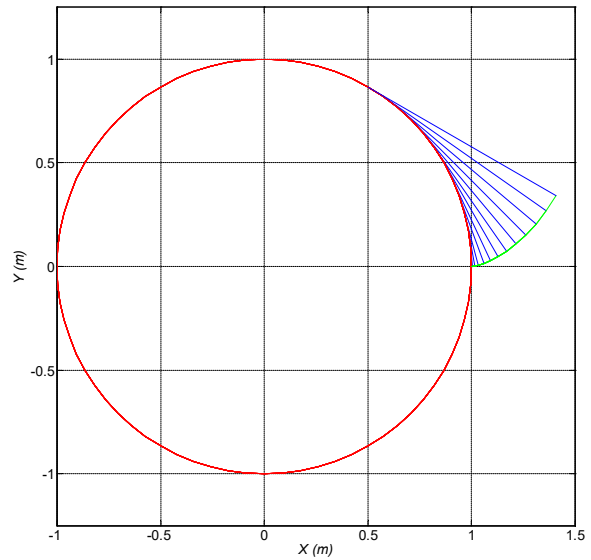

Involute Gear Tooth Construction

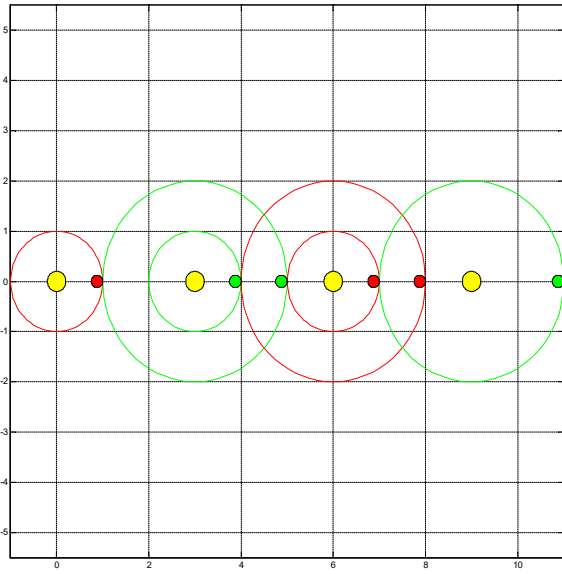
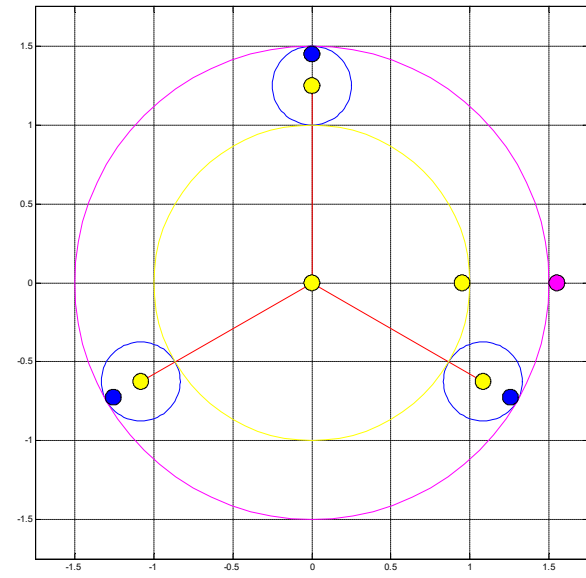
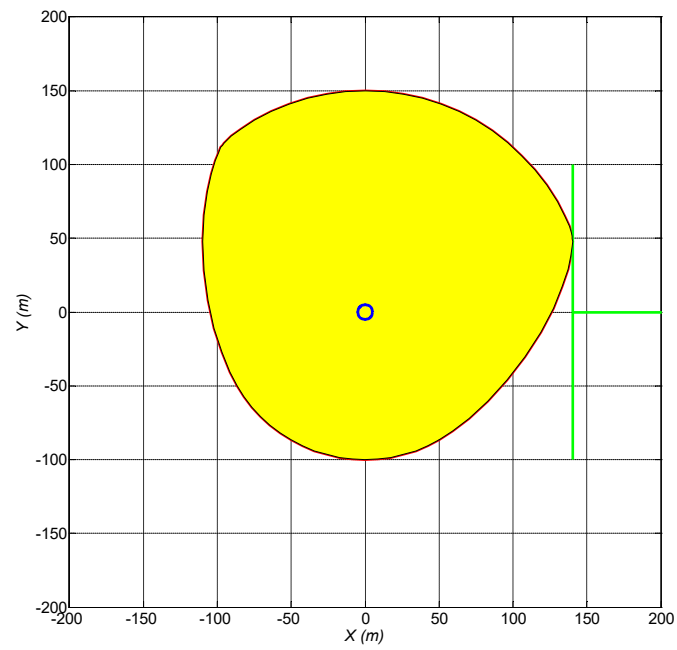
**Gearbox Simulation****Planetary Gear Train Simulation****Cam/Follower Animation**

Mechanical Vibrations

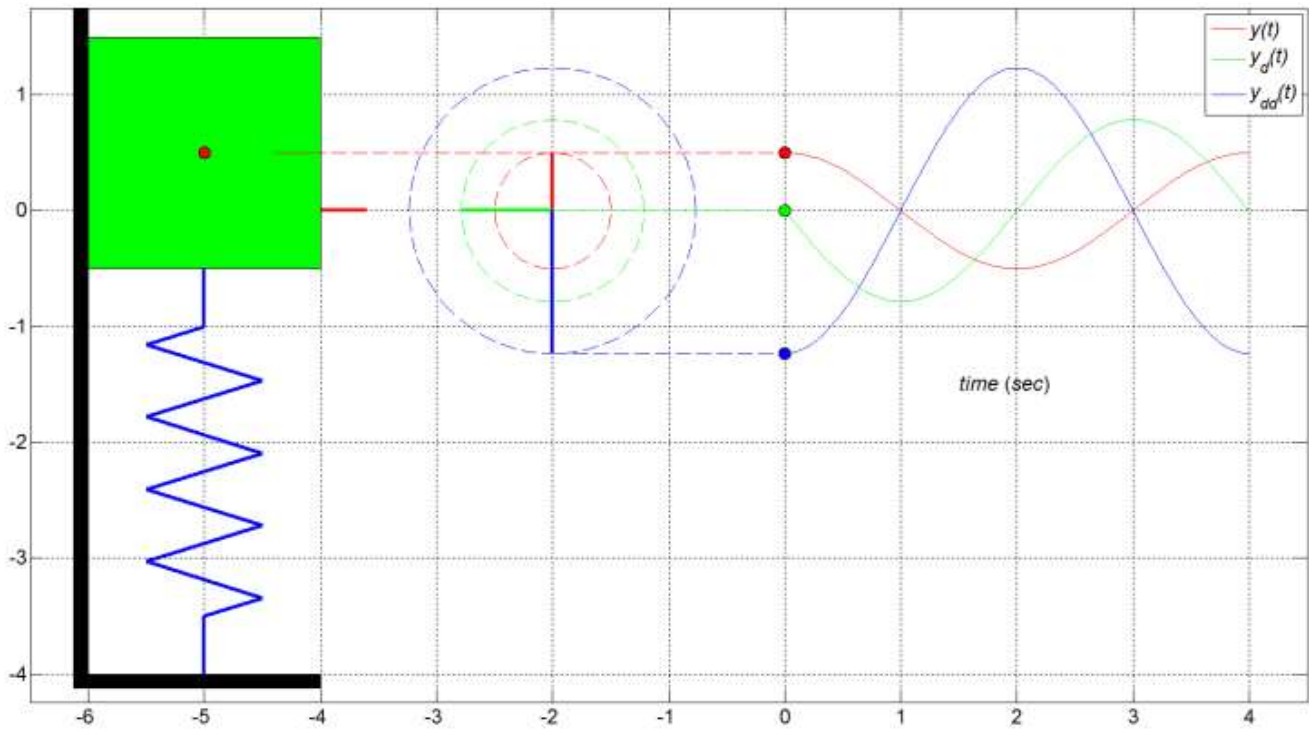

1-dof m-k Vibrational System, Undamped Simple Harmonic Motion, Rotating Phasors

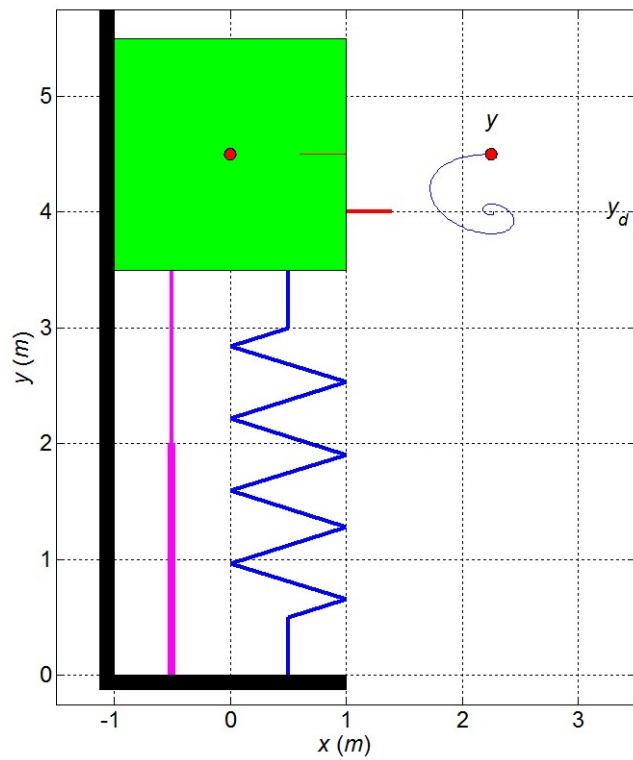

1-dof m-k Vibrational System, Underdamped Response with Phase Plot

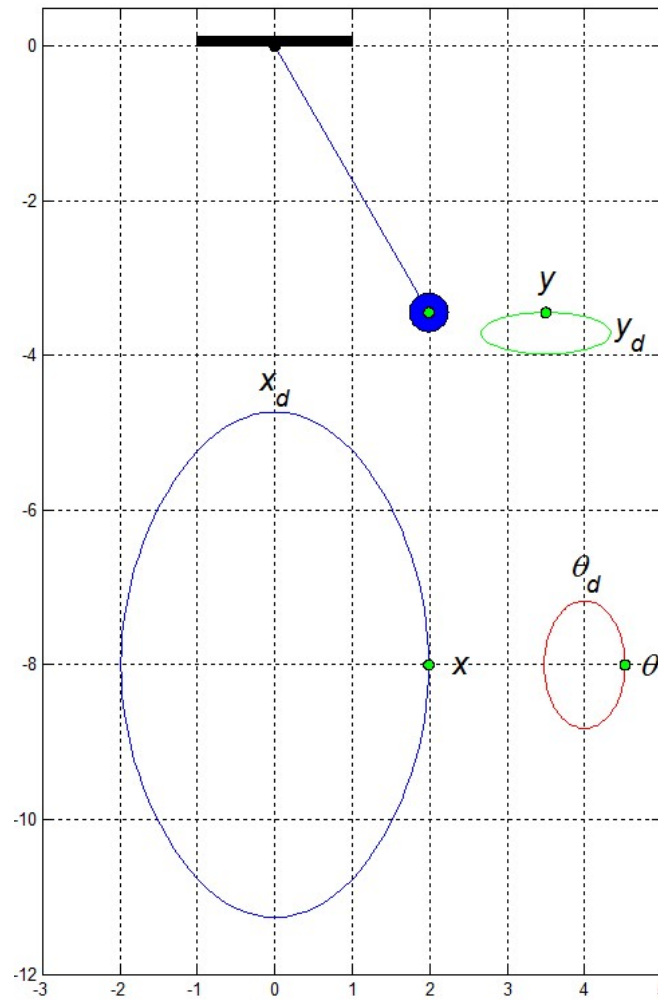

1-dof Pendulum Vibrational System, Simple Harmonic Motion with Phase Plots

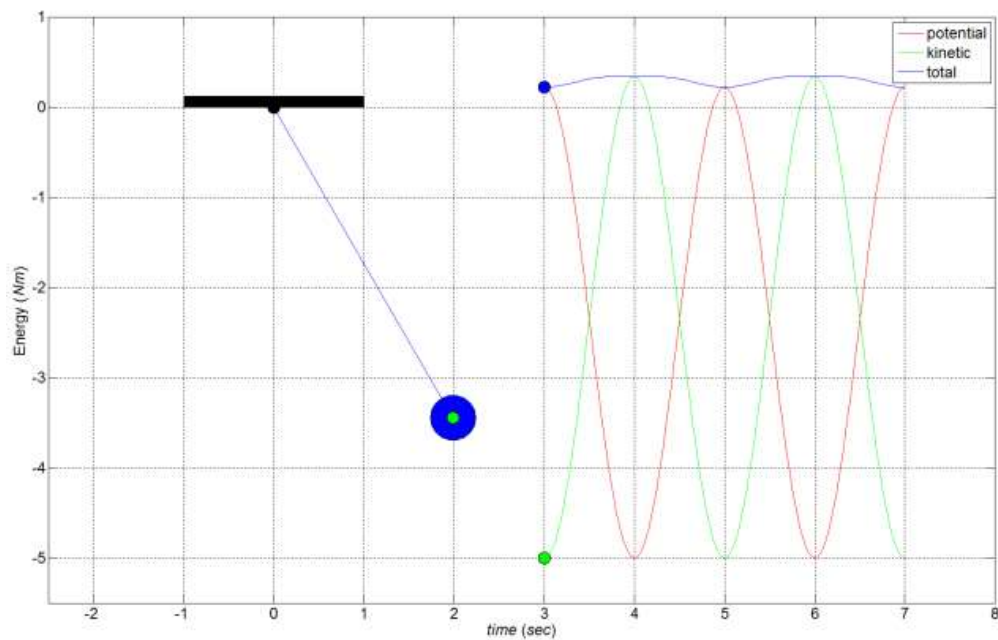

1-dof Pendulum Vibrational System, Simple Harmonic Motion with Energy Plot

ME 4290/5290 Mechanics of Robotic Manipulators

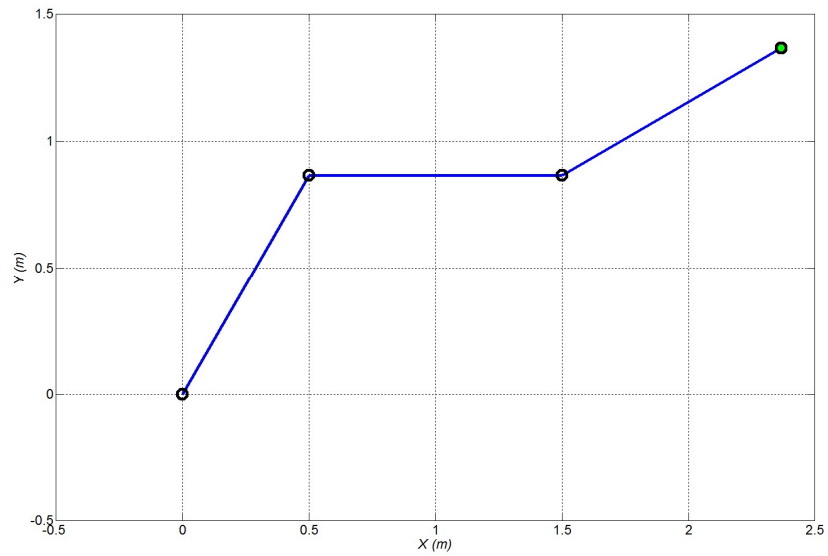

Planar 3R robot snapshot

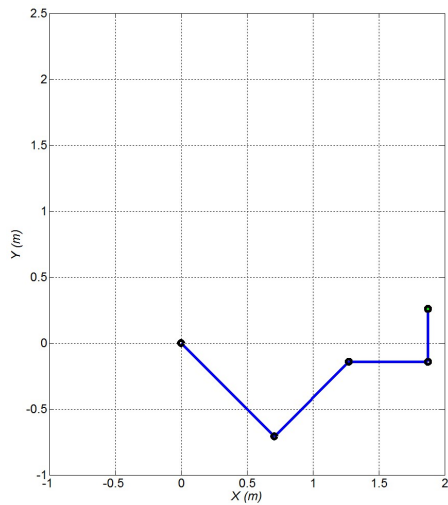

Initial Robot Pose

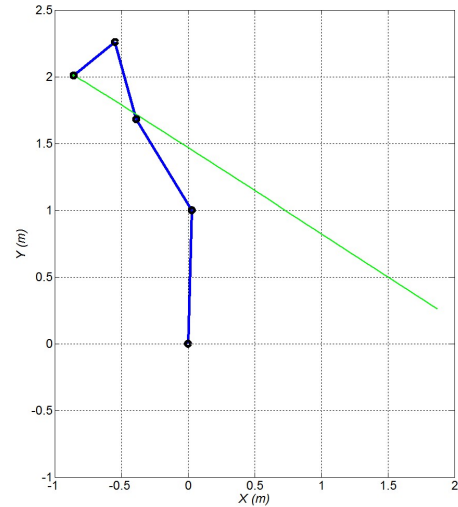

Final Robot Pose

Planar 4R Kinematically-Redundant Robot Resolved-Rate Control Simulation

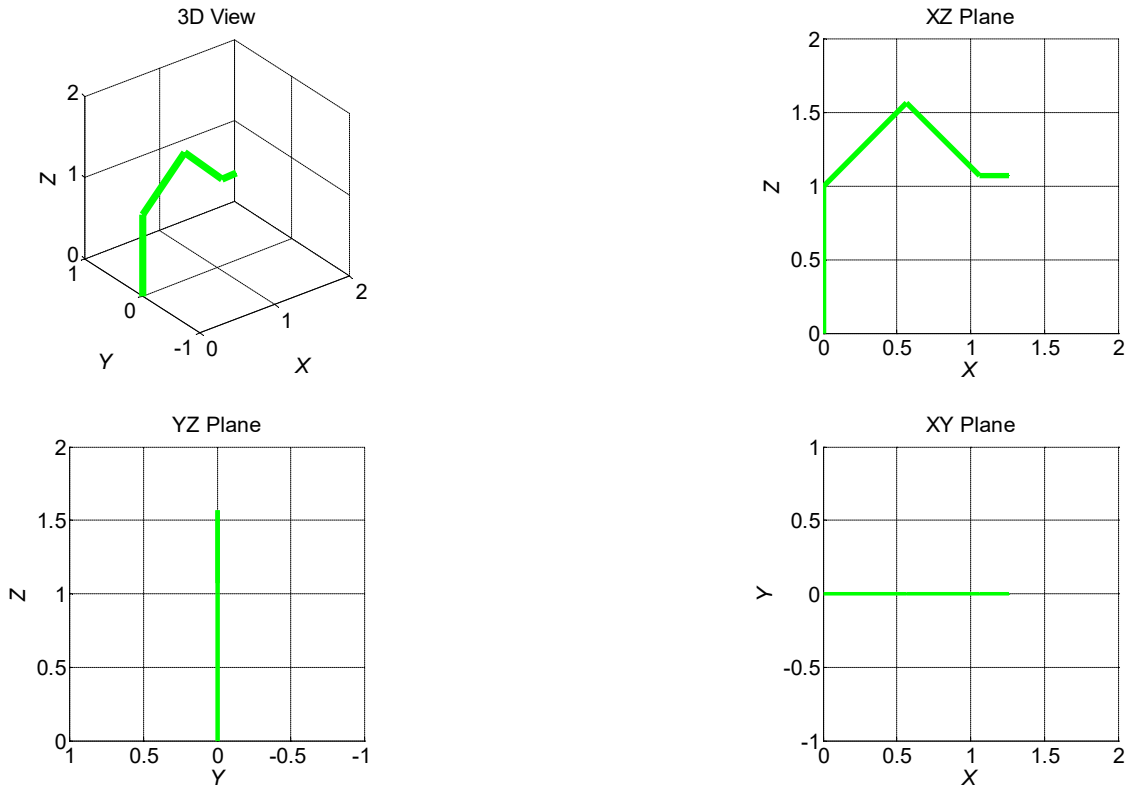

Spatial 4R Kinematically-Redundant Robot Resolved-Rate Control Simulation

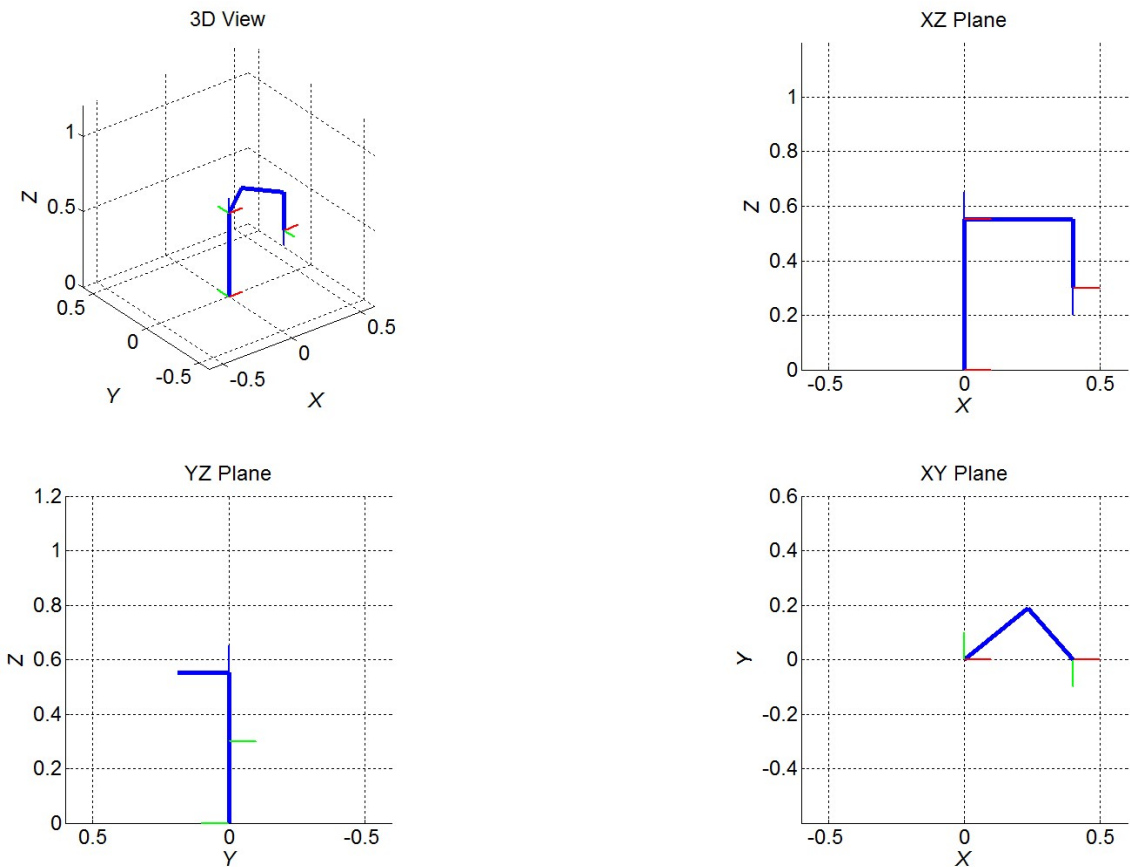

Adept 550 4-dof SCARA Robot MATLAB Simulation/Animation

ME 4670 / BME 5670 Biomechanics of Human Motion

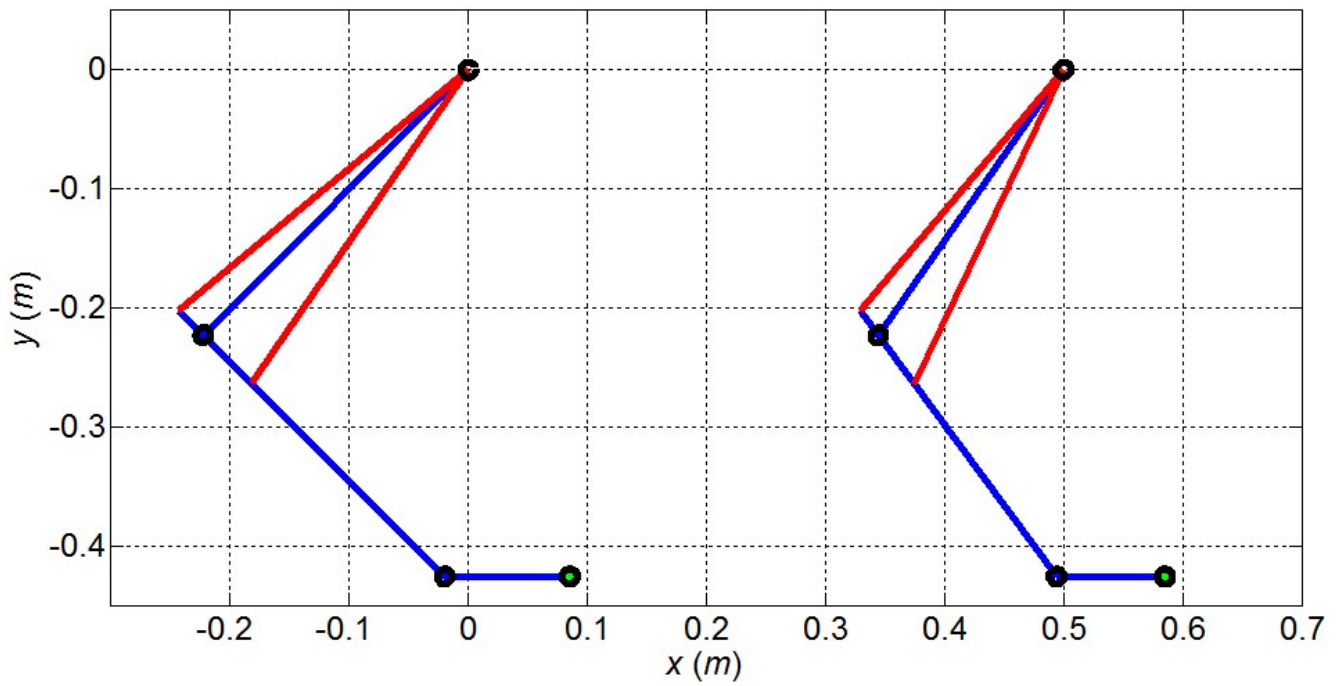

Inverse Pose Kinematics Snapshot
(male left, female right)

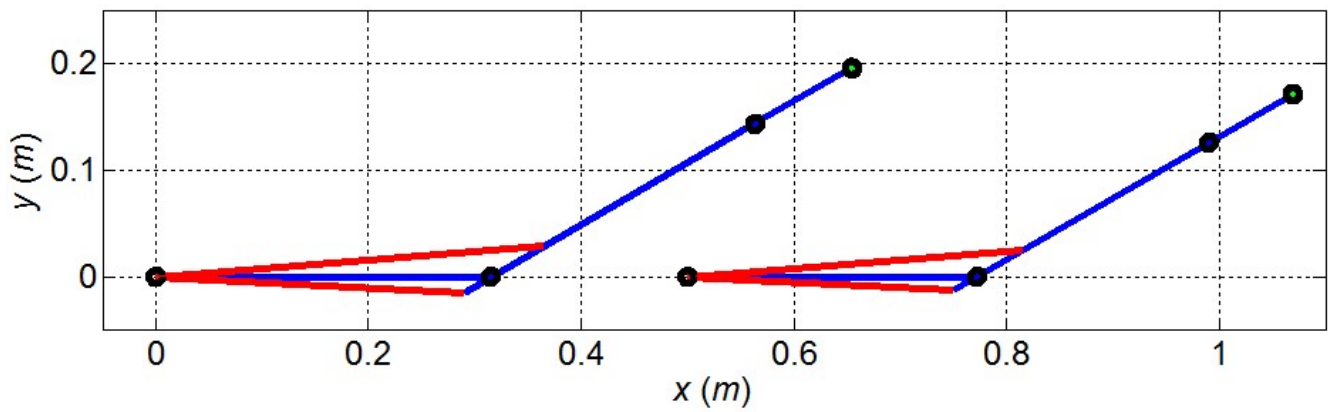

Human Elbow/Biceps/Triceps Dynamic Simulation (male left, female right)